



IP-Stile  
**KT-02.7**

ASSEMBLY AND OPERATION MANUAL

**CE EAC**



**IP-Style**

***KT-02.7***

**Assembly & Operation Manual**

# CONTENTS

1	Application.....	3
2	Operation conditions .....	3
3	Technical specifications .....	4
4	Delivery set.....	5
4.1	Standard delivery set .....	5
4.2	Optional devices and mounting hardware.....	5
5	Design and operation .....	7
5.1	Main features .....	7
5.2	IP-Stile design.....	7
5.2.1	IP-Stile housing .....	7
5.2.2	Indication module .....	9
5.2.3	RC-panel .....	9
5.2.4	IP-Stile controller .....	10
5.2.5	Algorithm of control mechanism operation .....	11
5.3	IP-Stile operation from the RC-panel .....	12
5.3.1	RC-panel connection.....	12
5.3.2	Control signals.....	13
5.4	IP-Stile optional equipment.....	14
5.4.1	Parameters of input signals <i>In1</i> , <i>In2</i> .....	14
5.4.2	<i>Out3</i> and <i>Out4</i> output signals.....	15
5.4.3	Connection to RS-485 interface .....	15
5.5	IP MODE and IP DEFAULT jumpers .....	16
5.6	Firmware update.....	16
6	Marking and packaging .....	17
7	Safety requirements .....	18
7.1	Installation safety .....	18
7.2	Safety during operation.....	18
8	Installation instructions.....	19
8.1	Installation details .....	19
8.2	Tools and equipment required for installation .....	19
8.3	Cable lengths.....	21
8.4	Installation sequence .....	22
9	Operation.....	25
9.1	Power-up .....	25
9.2	Configuration.....	25
9.3	IP-Stile control orders from the RC-panel .....	26
9.4	Operation as a part of an ACS.....	26
9.5	Access control mode, indication of controller events and states.....	28
10	Emergency actions.....	29
10.1	Emergency exit by use of anti-panic barrier arms.....	29
10.2	Mechanical unlocking.....	29
10.3	IP-Stile automatic unlocking.....	29
11	Troubleshooting.....	30
11.1	IP-Stile controller is not working.....	30
11.2	IP-Stile controller is not recognized by the PC .....	30
12	Maintenance.....	31
13	Transportation and storage .....	32
	Appendix 1. Algorithm of control signals generation during standalone operation.....	33
	Appendix 2. Connection through PoE-splitter .....	34

## ***Dear Customer!***

*Thank you for purchasing PERCo IP-Stile.  
Please follow instructions given in this Manual carefully,  
and this quality product will provide many years of trouble-free use.*

This Assembly & Operation Manual of the **KT-02.7 IP-Stile** (hereinafter – the Manual) contains data on transportation, storage, installation, operation and maintenance of the product.

Installation of the product must be carried out by skilled workers in strict accordance to this Manual.

Abbreviations adopted in the Manual:

LAN – local area network;  
ACS – access control system;  
RC-panel – remote control panel;  
WRC – wireless remote control.

## **1 APPLICATION**

**KT-02.7 IP-Stile** (hereinafter – IP-Stile) is designed for control of access to a facility by means of proximity cards. Access control through IP-Stile is performed by the operator with the RC-panel, which is included in the standard delivery set or, using **PERCo-Web** software, with the proximity cards.

IP-Stile can operate either as a standalone unit, without permanent connection to the local network or a PC, or as a part of **PERCo-Web** security system. All the registered events are logged in the nonvolatile memory of the IP-Stile controller. As a part of **PERCo-Web** ACS supports all the performance capabilities of the system.

Number of IP-Stiles, required for quick and comfortable passageway should be defined on the base of IP-Stile throughput rate, stated in Section 3 It is recommended to install one IP-Stile per each 500 people working the same shift or at the rate of 30 persons per minute at the peak mode.

## **2 OPERATION CONDITIONS**

IP-Stile, with regard to resistance to environmental exposure, conforms to category NF4 (operation in premises with climate control) according to GOST 15150-69.

IP-Stile operation is allowed at ambient temperature from +1°C to +40°C and relative air humidity up to 80% at +25°C.

### 3 TECHNICAL SPECIFICATIONS

Operating voltage <sup>1</sup> .....	12±1.2 V
Consumption current .....	max. 0.8 A
Maximum power consumption .....	max. 10 W
Throughput capacity in single passage mode .....	30 persons / min
Throughput capacity in free passage mode .....	60 persons / min
Passageway width .....	500 mm
Maximum barrier arm rotation force .....	max. 3.5 kgf
Number of readers .....	2
The type of access cards .....	<i>MIFARE Classic, Plus, Ultralight, DESFire</i>
Minimum card reading distance .....	3 – 6 cm
Number of users (access cards) .....	up to 50000
Event memory capacity <sup>2</sup> .....	up to 135000
Number of built-in controller inputs .....	2
Number of built-in controller relay outputs .....	2
Communication interface standard .....	<i>Ethernet (IEEE 802.3)</i>
RC-panel cable length <sup>3</sup> .....	min. 6.6
Ingress Protection Rating.....	IP41 (EN 60529)
Electric shock protection class .....	III (IEC 61140)
Mean time to failure .....	1,500,000 passages
Mean lifetime .....	8 years
Web-interface .....	there's
Overall dimensions with barrier arms (L×W×H) .....	640×683×1040 mm
Maximum net weight .....	max 34 kg



**Note:**

At the production stage the controller is assigned a unique physical address (MAC-address) and IP-address (given in the label of the processor microchip), the subnet mask (255.0.0.0) and IP-address of the gateway (0.0.0.0). The controller provides capability of firmware update through the *Ethernet*.

<sup>1</sup> It is recommended to use 12 VDC power supply with linear stabilization of voltage and pulsation amplitude at output not exceeding 50 mV.

<sup>2</sup> In case the IP-Stile controller event log is overloaded, new events replace the oldest ones; the events are deleted in blocks of 256 events.

<sup>3</sup> Maximum allowable length of RC panel cable is 40 m.

## 4 DELIVERY SET

### 4.1 Standard delivery set

#### Basic equipment:

IP-Stile housing with the <b>CT-03</b> controller board installed .....	1
Barrier arm .....	3



#### Note:

The barrier arms are itemized separately in the price list, type chosen by the Customer at the time of order. There are two types of barrier arms: «Standard» – **AS-01**; «Anti-panic» – **AA-01**.

Key to housing top cover lock .....	2
Mechanical release key .....	2
RC-panel with cable .....	1
Jumper .....	4

#### Mounting hardware:

Self-adhesive cable tie mount .....	3
Hook and loop cable tie 100 mm .....	6
Insulation bushing .....	2
Plug Ø 30 mm .....	5

#### Spare parts:

Plug Ø 30 mm .....	1
--------------------	---

#### Software:

Software <b>PERCo</b> (DVD) .....	1
-----------------------------------	---

#### Operational documentation:

Certificate .....	1
Assembly & Operation Manual .....	1
User Guide .....	1

#### Package:

Transportation box .....	1
--------------------------	---

### 4.2 Optional devices and mounting hardware

Optional devices and mounting hardware can be supplied to customer order. Technical specifications of optional devices are given in corresponding documentation to the same devices.

#### Optional devices:

Power supply unit .....	1
PoE-splitter <sup>1</sup> .....	1
Intrusion detector and siren .....	1
Wireless remote control <sup>2</sup> .....	1
System time panel <b>AU-05</b> .....	1

#### Optional mounting hardware:

PFG IR 10-15 anchor bolts (by SORMAT, Finland) .....	4
--	---

<sup>1</sup> PoE-splitter – allows energizing the IP-Stile via *Ethernet* network. Splitter may be used along with network commutators that support the technology of energizing via PoE twisted pair and compatible with *IEEE 802.3af* standard.

<sup>2</sup> WRC kit consists of a receiver and transmitters (tags) with operation range up to 40 m.

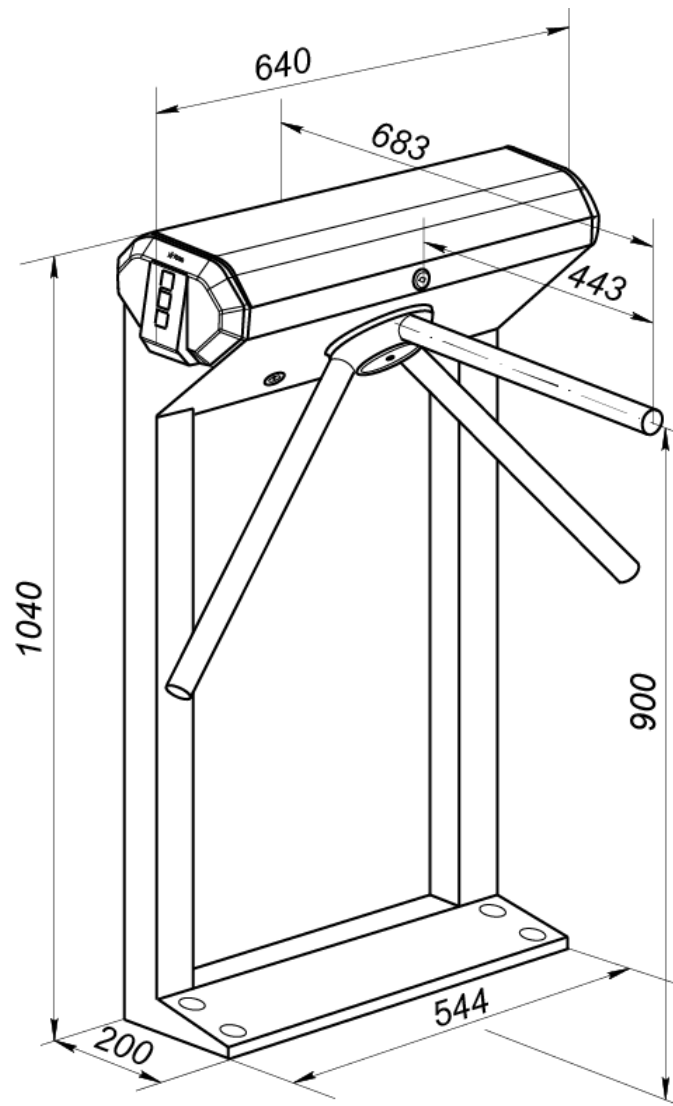

**Figure 1. IP-Style Overall dimensions**

## 5 DESIGN AND OPERATION

### 5.1 Main features

- IP-Stile can operate either as a standalone unit from the RC-panel or WRC.
- IP-Stile can operate as a part of **PERCo-Web** system. In this case the access control is performed with the proximity cards. As a part of ACS the IP-Stile provides:
  - operation in ACM: «Open», «Control», «Closed»;
  - saving the set ACM in the nonvolatile memory for keeping the ACM from changes in case of power failure;
  - local and global location monitoring, double-check access and verification, function support.
- End faces of the IP-Stile housing have covers with mnemonic indicators of proximity card readers installed under them inside the housing.
- IP-Stile controller can operate with proximity cards of up to 64 bit code.
- IP-Stile controller provides: connection through *Ethernet* interface, (support of the protocol stack TCP/IP (ARP, IP, ICMP, TCP, UDP, DHCP).
- IP-Stile is equipped with Web-interface aimed at making major settings.
- Possibility of IP-Stile firmware update through *Ethernet*.
- All the logged events are saved in the IP-Stile controller nonvolatile memory, so that they could be browsed in future.
- IP-Stile uses safe voltage supply– maximum 14 V.
- Low energy consumption – maximum 10 W.
- A resetting mechanism ensures automatic reset of barrier arms to home position after each passage.
- Smooth and quiet operation of the IP-Stile is ensured by a damper.
- To ensure correct register of passages the resetting mechanism has built-in optic rotation sensors.
- The built-in mechanical release lock ensures safe emergency unlocking with a key providing free rotation of the barrier arms.
- Installed in a line several IP-Stiles form a secured passageway without installation of extra guide barriers.

### 5.2 IP-Stile design

The IP-Stile design is given in Figure 2, the numbers of the parts in the Manual being designated accordingly. The overall dimensions are given in Figure 1. IP-Stile consists of housing with an built-in controller and two readers, three barrier arms and a RC-panel (ref. Figure 2, parts 1-3, 5 and 9).

#### 5.2.1 IP-Stile housing

The housing is fixed to the floor with four anchor bolts through the holes in the base (2). Internal elements of the housing are accessed through a removable top cover (3) which should be locked at normal operation with a top cover lock (4).

Inside the IP-Stile there are:

- IP-Stile controller.
- Two proximity card readers. The readers are located under the front covers.
- Barrier arms rotary group consisting of (Figure 14):
  - control mechanism with optic sensors;
  - rotation mechanism, including a resetting mechanism (a pusher, stop springs, and a roller); a damper; locking device, which precludes the possibility of intrusion;
  - mechanical release lock (7).



The point of attachment of the barrier arms to the rotating mechanism is hidden with a cover (6).

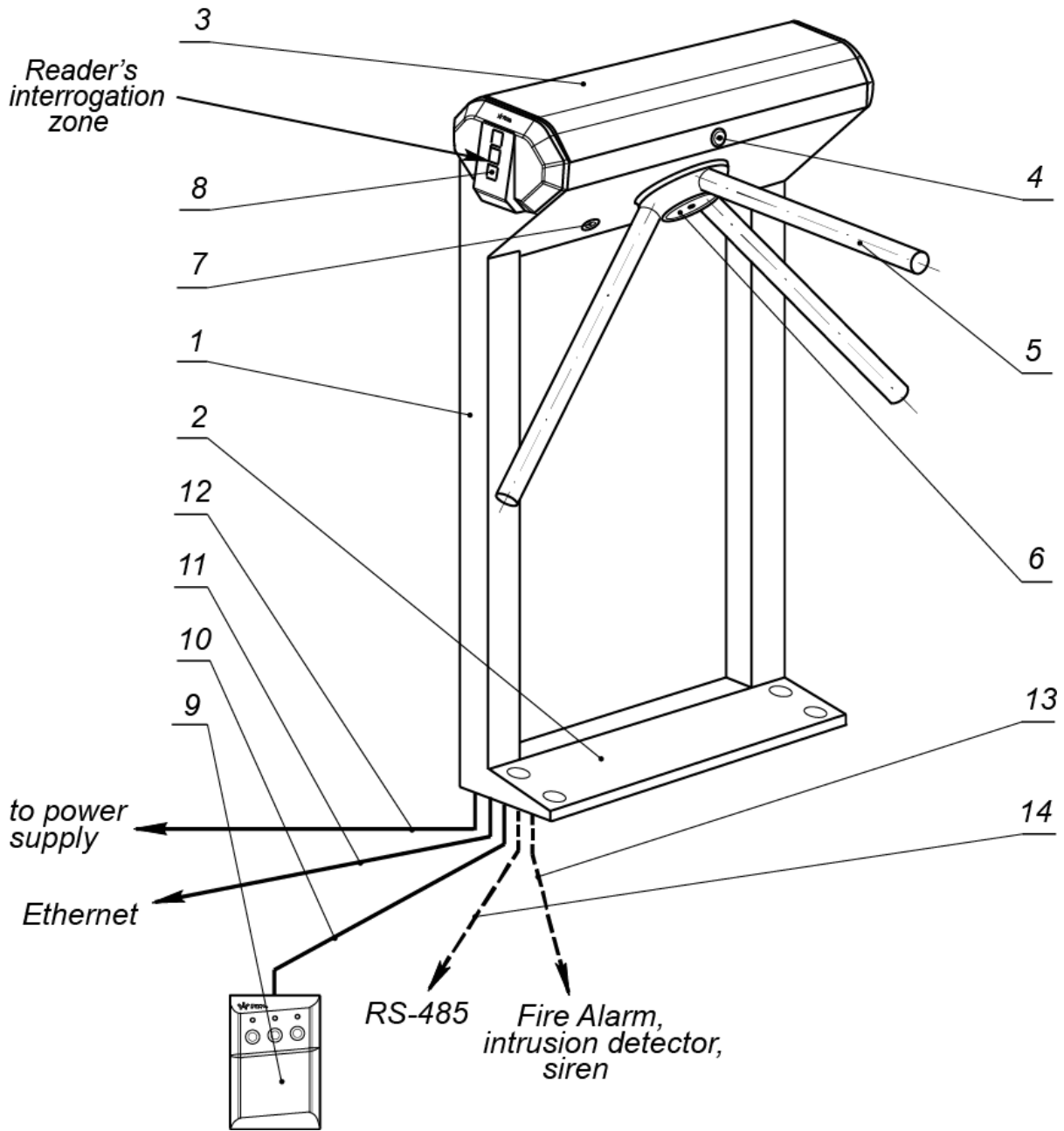

**Figure 2. IP-Stile design:**

**Standard delivery set:**

- 1 – frame; 2 – base; 3 – top cover; parts 1-3 make housing; 4 – top cover lock;
- 5 – barrier arm, 6 – cap to cover barrier arms adjusting points;
- 7 – mechanical release lock; 8 – indication module;
- 9 – RC-panel; 10 – RC-panel cable

**Not included in standard delivery set:**

- 11 – LAN connection cable; 12 – power cable;
- 13 – cable to devices emergency unblocking (*Fire Alarm*), intrusion detector and siren;
- 14 – Data cable to additional devices via RS-485

## 5.2.2 Indication module

Indication modules (8) are located in the IP-Stile end faces housing. They inform about the current status of the IP-Stile. Both end faces of the housing feature indication modules (8) with built-in card readers. The indication module has 3 mnemonic indicators (Figure 3):



- Green indicator of authorized passage.  
IP-Stile is unlocked in this direction.
- Yellow indicator: card presentation or operator commands are expected.  
IP-Stile is locked in this direction.
- Red indicator of passage ban.  
IP-Stile is locked in this direction.

**Figure 3. Mnemonic indicators of the indication module**

## 5.2.3 RC-panel

RC-panel (9) is connected to the IP-Stile housing with an RC-panel cable (10). RC-panel design and overall dimensions are shown in Figure 4.

The RC-panel features 3 buttons to set operating modes of the IP-Stile. The button in the middle **STOP** serves for setting the “Always locked” operating mode, the **RIGHT** and **LEFT** buttons – for unlocking the IP-Stile in a chosen direction. Up above the buttons there is an LED indication of the set mode. IP-Stile manual operation modes and RC-panel indication are shown in Table 6).

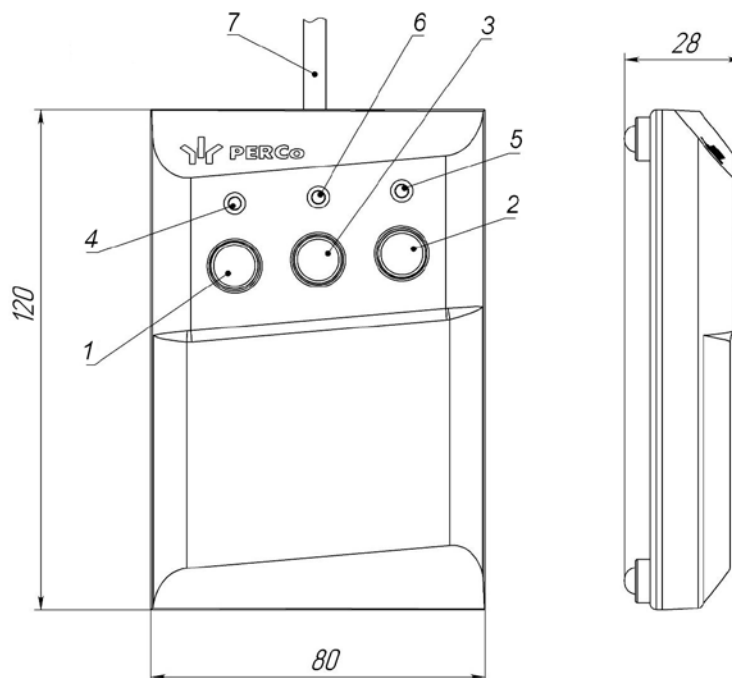

**Figure 4. RC-panel design and overall dimensions**

- 1, 2, 3 – **LEFT**, **RIGHT**, **STOP** buttons mode setting;
- 4, 5 – «*Left*», «*Right*» green light indicators;
- 6 – «*Stop*» red light indicator; 7 – RC-panel cable.

### 5.2.4 IP-Stile controller

**CT-03** controller (hereinafter – *IP-Stile controller*) is installed inside the IP-Stile housing. Controller configuration is shown on Figure 5.

The Figure features connectors and connector blocks for IP-Stile configuration and external communication connection:

- **XT1 (In)** – connector block to connect additional inputs.
- **XT2** – connector block to connect the RC-panel / the WRC.
- **XT3 (RS-485)** – connector block to connect proximity card readers and **AU-05** system time display.
- **XT4 (+12VDC)** – connector block to connect power supply.
- **XT7 (Out)** – connector block to connect additional outputs.
- **X2 (Control)** – connector for control mechanism.
- **S1** – connector block to connect LAN over *Ethernet* (IEEE 802.3).
- **XP1** and **XP3.1 - XP3.3** – connectors to install jumpers.
- **Power** – red LED indicator of power supply to the controller board.
- **Out 3, Out 4** – red LED indicators of power supply to the corresponding output relay winding.

Connector block contacts application is stated in Table 1.

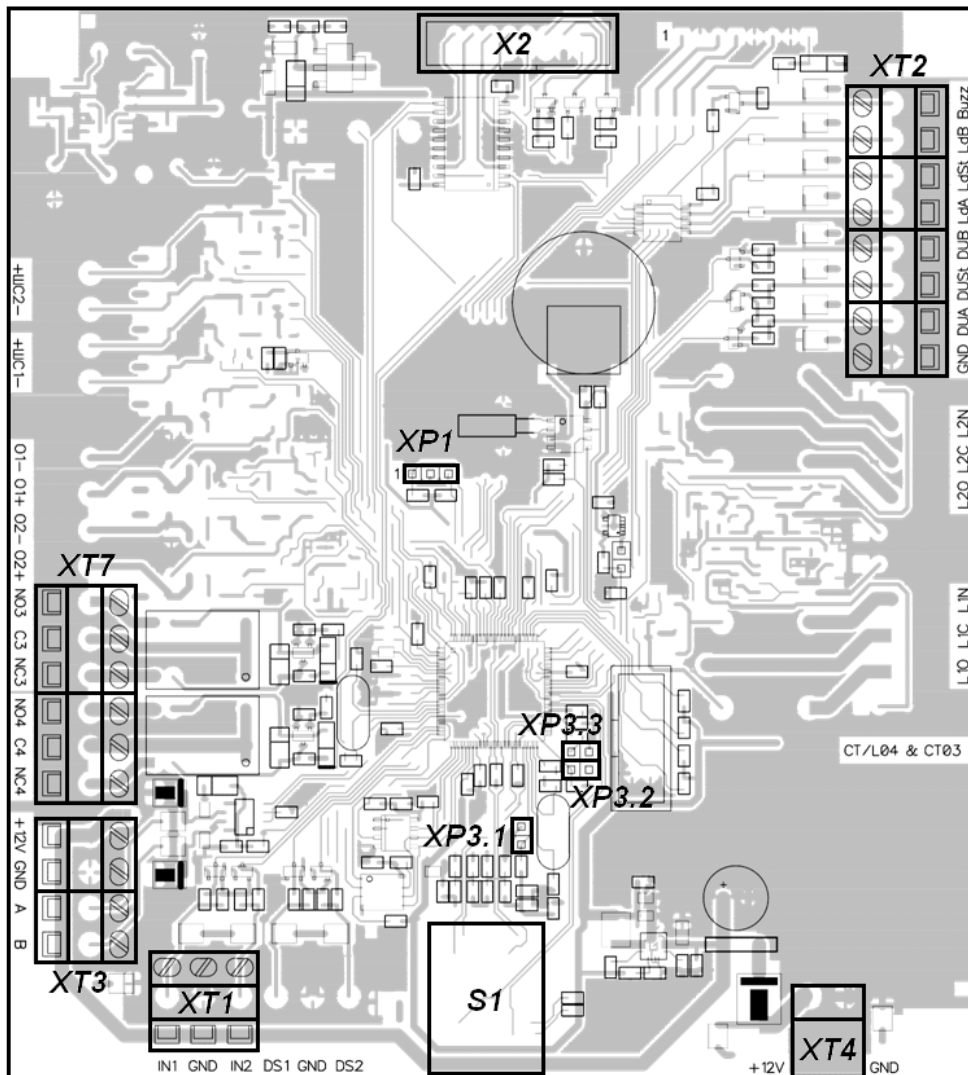

Figure 5. CT-03 controller board

IP-Stile controller board features: a microcontroller, a nonvolatile memory, nonvolatile RTC-timer (real-time clock).

The following devices are connected to the controller with the cables: control mechanism, readers, *Fire Alarm*, *Ethernet* network. IP-Stile power supply is performed through the power cable (12). All connections are performed in accordance with the IP-Stile and optional equipment electric connection layout shown at Figure 12.

**Table 1. Function of connector block contacts**

No	Contact	Function
<b>XT1 Connector</b>		
1	<i>In1</i>	Additional input 1
2	<i>GND</i>	General
3	<i>In2</i>	Additional input 2
<b>XT2 Connector</b>		
1	<i>GND</i>	General
2	<i>DUA</i>	Input A of RC-panel
3	<i>DUS<sub>t</sub></i>	Input STOP of RC-panel
4	<i>DUB</i>	Input B of RC-panel
5	<i>Ld A</i>	Indication output A of RC-panel
6	<i>Ld St</i>	Indication output STOP of RC-panel
7	<i>Ld B</i>	Indication output B of RC-panel
8	<i>Buzz</i>	RC-panel audio signal indication output
<b>XT3 Connector</b>		
1	<i>+12V</i>	+12 V reader power connection
2	<i>GND</i>	General
3	<i>A</i>	Line A powering through RS-485
4	<i>B</i>	Line B powering through RS-485
<b>XT4 Connector</b>		
1	<i>+12V</i>	+12V external OD connection
2	<i>GND</i>	General
<b>XT5 Connector</b>		
1	<i>L1O</i>	Lock 1 relay output, normally-open contact
2	<i>L1C</i>	Lock 1 relay output, central contact
3	<i>L1N</i>	Lock 1 relay output, normally-closed contact
<b>XT6 Connector</b>		
1	<i>L2O</i>	Lock 2 relay output, normally-open contact
2	<i>L2C</i>	Lock 2 relay output, central contact
3	<i>L2N</i>	Lock 2 relay output, normally-closed contact
<b>XT7 Connector</b>		
5	<i>NO3</i>	<i>Out 3</i> relay output, normally-open contact
6	<i>C3</i>	<i>Out 3</i> relay output, central contact
7	<i>NC3</i>	<i>Out 3</i> relay output, normally-closed contact
8	<i>NO4</i>	<i>Out 4</i> relay output, normally-open contact
9	<i>C4</i>	<i>Out 4</i> relay output, central contact
10	<i>NC4</i>	<i>Out 4</i> relay output, normally-closed contact

### 5.2.5 Algorithm of control mechanism operation

IP-Stile operation algorithm at receiving a command to a controller for a single passage in A/B direction:

1. If the access is granted, the IP-Stile controller sends a command for rotary group unlocking in the A/B direction to the control mechanism. The countdown of **Holding in unlocked state** begins.

2. The control mechanism unlocks the possibility of rotary group turn in A/B direction (lift the key holt upper / lower side). It becomes possible to perform the passage in the given direction.
3. The controller follows the status of the optic rotation sensors that are activated/ deactivated in a certain sequence during rotation of the barrier arms and counts the time since pressing of the button responsible for passage authorization in the direction A(B).
4. When the barrier arms rotate 67°, the controller registers a passage in the corresponding direction. After the barrier arms rotate 67°, or the time since the moment of pressing of the A(B) direction button exceeds the passage waiting time, the controller generates a command for the control mechanism to close the passage in the A(B) direction (the upper (lower) end of the key holt is lowered). From this moment the controller is ready to execute the next command in this direction
5. If the rotation of the barrier arms does not start, the rotary group gets locked after the end of the **Holding in unlocked state** countdown.
6. The IP-Stile is ready for the next passage.

## 5.3 IP-Stile operation from the RC-panel

### 5.3.1 RC-panel connection

RC-panel / WRC connection for IP-Stile standalone operation is performed to the following **XT2** connector block contacts (RC-panel power supply is connected to the +12V **XT4** connector block contact):

- *DUA, DUS<sub>t</sub>, DUB* – control inputs;
- *LdA, LdSt, LdB, Buzz* – RC-panel light and audio signal indication control output (indication on the RC-panel fob is not provided).

Pressing the buttons on the RC-panel or on the WRC results in forming a control signal on the corresponding controller input. RC-panel and WRC can be connected to the IP-Stile separately or simultaneously. In case both devices are connected simultaneously, the incoming control signals can overlap each other, so the IP-Stile reaction will correspond to the one for control signal combination.

Standard RC-panel orientation regarding IP-Stile post is shown at Figure 6. The RC-panel orientation can be reversed. In order to do that it is necessary to change the RC-panel cable connection points to the **XT2** connector block contacts when connecting the RC-panel according to the electric connection scheme (Figure 12).

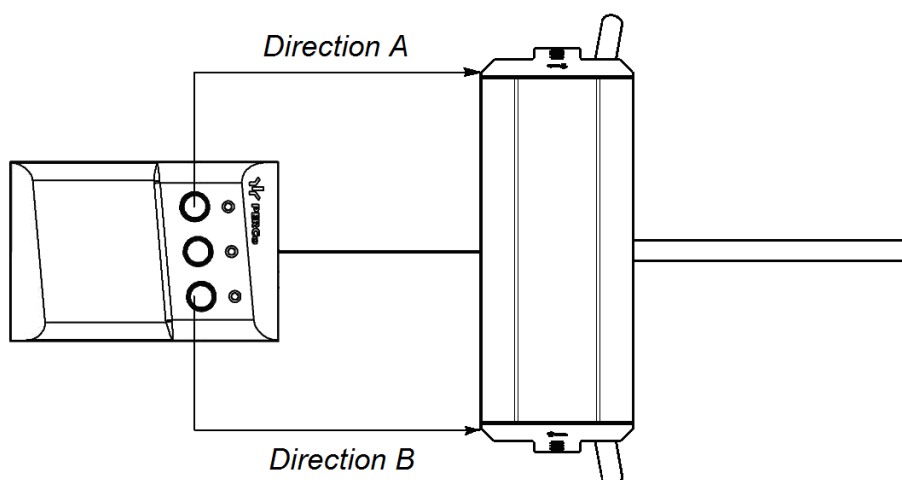

**Figure 6. Standard RC-panel orientation regarding IP-Stile**

**Table 2. RC-cable connection to the XT2 connector block contacts for standard and reverse RC-panel orientation**

№	Contact	RC-panel orientation	
		Standard	Reverse
1	<i>GND</i>	black	black
2	<i>DU A</i>	white	green
3	<i>DU St</i>	blue	blue
4	<i>DU B</i>	green	white
5	<i>Ld A</i>	yellow	red
6	<i>Ld St</i>	orange	orange
7	<i>Ld B</i>	red	yellow
8	<i>Buzz</i>	brown	brown

### 5.3.2 Control signals

IP-Stile operation is performed by sending a control signal to the *DUA*, *DUB* and *DUST* controller inputs. Input activation results in closing of the *DUA(B)* contact with the *GND* contact (i.e. generation at the *DUA(B)* contact of a low-level signal relative to the *GND* contact). The minimum duration of an input signal for operating mode change is 100 ms. Control signal sending algorithms are described in the Appendix 1. IP-Stile operation (as a standalone unit) modes and indication are shown in Table 6.



#### Note:

In case *DUA*, *DUB* and *DUST* inputs are not connected, the high level signal is to be generated. It can be generated with the help of resistors of 2 kOhm strength, connected to the +3.3 V voltage plane.

Normally-open relay contact or an open collector relay figure (Figure 7 and Figure 8) can serve as a control element. The control element is to provide the following characteristics of the signals:

Control element – relay contact:

Minimal commutated current ..... no more than 1 mA

Resistance of a closed contact

(with connection cable resistance taken into account) ..... no more than 300 Ohm

Control element – circuit with open-collector output:

Voltage at a closed contact

(a low-level signal, at the input of the controller) ..... no more than 0.8 V

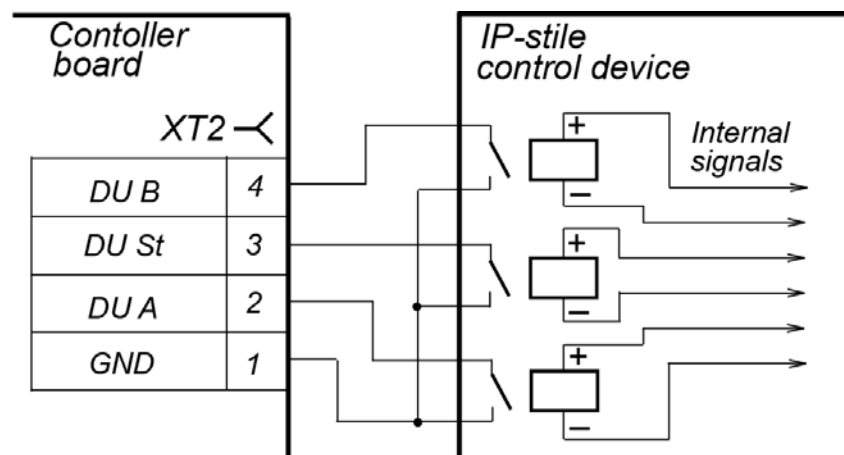

**Figure 7. Control elements of IP-Stile control device: normally open relay contact**

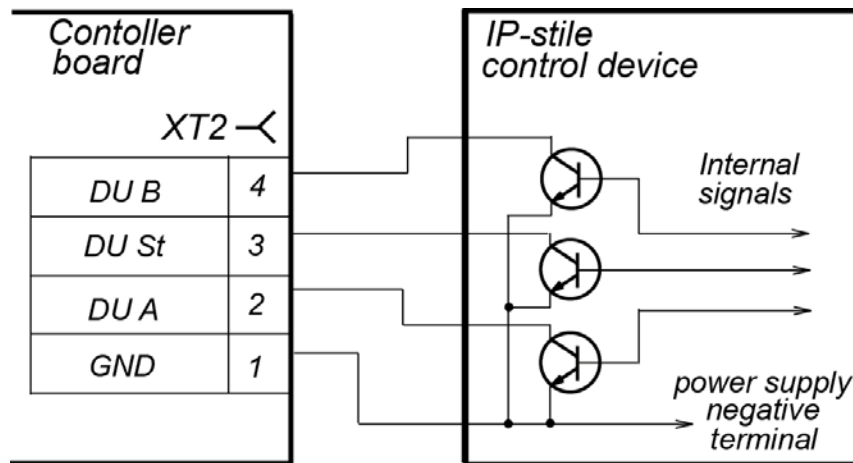

Figure 8. Control elements of IP-Stile control device: circuit with open-collector output

## 5.4 IP-Stile optional equipment

The following equipment can be connected to the IP-Stile:

- Control device (RC-panel, WRC)
- ID and a siren.
- *Fire Alarm*;
- **AU-05** system time display;

Connector block positioning on the IP-Stile board is shown on Figure 5. The use of connector block contacts is described in Table 1. The connection scheme is provided at Figure 12. The used cables are stated in Table 4.

### 5.4.1 Parameters of input signals *In1*, *In2*

*In1*, *In2* inputs can be used only when the IP-Stile operates as a part of **PERCo-Web** system. Connection to the inputs is performed through *GND*, *In1* and *In2* contacts and the IP-Stile **XT1** connector block.

The controller provides status control of 2 inputs controlled by dry contacts or OK, performing the following functions: *In1*, *In2*. The inputs can be used for connection of:

- ID,
- *Fire Alarm*,
- Receiving notification from other additional equipment.



#### **Attention!**

ID installation on the IP-Stile housing is to be performed only at the manufacturing plant.

Activation evidence of *In1*, *In2* signals depends on the description of their initial condition by the **Normal contact state parameter** in **PERCo-WEB** software:

- If an input is assigned as “normally open” its activation is done then by means of a low-level signal relative to the *GND* sent to it. A normally open relay contact or a circuit with open-collector output can be used as the control element.
- If an input is assigned as “normally closed” its activation is done by withdrawing of a low-level signal relative to the *GND* from it. A normally closed relay contact or a circuit with open-collector output can be used as the control element.

**Note:**

All the unconnected inputs are pulled up to the power supply. To generate the high level signal on all the input contacts (*In1*, *In2*) use resistors of 2 kOhm strength, connected to the +3,3 V voltage plane.

The control element is to provide the following characteristics of the signals:

Minimal commutated current ..... no more than 1 mA

Resistance of a closed contact

(with connection cable resistance taken into account) ..... no more than 300 Ohm

Control element – circuit with open-collector output:

Voltage at a closed contact

(a low-level signal, at the input of the controller) ..... no more than 0.8 V

**FireAlarm input**

IP-Stile can be operated from the *Fire Alarm* device. IP-Stile gets unlocked for passage in both directions. All control commands are ignored.

To switch the IP-Stile in *Fire Alarm* mode the control signal is to be sent from the *Fire Alarm* device to the IP-Stile controller additional input. At the configuration of the input, to which the *Fire Alarm* device is connected in the **PERCo-Web** software of the corresponding **Additional input** resource, there should be chosen the **type: Fire Alarm** (or **Type: Special**, and the checkboxes of the **Acquit alarm (Alarm generator)**, **Acquit alarm (Output «C» of fire and security alarm)** parameters are to be cleared).

To exit the *Fire Alarm* mode remove the control signal from the entrance.

**5.4.2 Out3 and Out4 output signals**

*Out3* and *Out4* outputs can be used only if the IP-Stile operates as a part of **PERCo-Web** system. Connection to the outputs is performed through the *NO3*, *C3* and *NC3* and *NO4*, *C4* and *NC4* contacts of the IP-Stile controller board **XT7** connector block.

Relay outputs *Out3* and *Out4*, having complete group of contacts (normally-open *NO*, normally-closed *NC* and common output *C* contacts).

The outputs can be used for:

- light and sound signal control (siren),
- alarm signal transmission to the central monitoring RC-panel,
- additional equipment control.

The outputs have the following signal parameters:

Maximum commutated voltage, DC ..... no more than 30 V

Maximum commuted voltage, AC ..... no more than 42 V

Maximum commutated DC/AC for outputs ..... no more than 2 A

Closed contact resistance ..... no more than 0.15 ohm

**5.4.3 Connection to RS-485 interface**

**AU-05** system time display can be connected to the IP-Stile. The connection is performed through **XT3** connector block contacts.

Connecting several devices through RS-485 interface, each communication line is to be connected consequently to all devices. On the communication line ends there should be placed end-of-line resistors.

If the controller is installed on one of the communication line ends, it is necessary to install a resistor of 120 Ohm strength between A and B contacts of the **XT3** connector block.



## 5.5 IP MODE and IP DEFAULT jumpers



### **Attention!**

Jumper installation and removal are to be carried out only when the equipment is turned off.

The IP-address is set by jumper installation and removal at the **XP1** IP-Stile controller board connector. Connector location is shown at Figure 5.

**Table 3. Variants of jumper installation on XP1 connector**

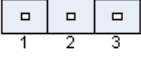
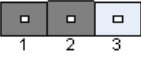
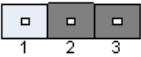
No	Jumper position on XP1	Mode
1		The jumper removed
2		<b>IP MODE</b>
3		<b>IP DEFAULT</b>

The IP-address can be set as followed:

1. Jumper removed.

- If the IP-address (gateway, subnet mask) has not been changed by the user, the controller will operate with the initial settings: IP-address and MAC-address are stated in the IP-Stile certificate on the controller board; subnet mask 255.0.0.0; gateway IP-address 0.0.0.0.
- If the IP-address (gateway, subnet mask) has been changed, the controller starts to operate with the new settings immediately.



### **Note:**

Controller network settings change is possible only from the PC through the Web-interface or from the Software. At that the controller and the PC are to be in one subnet.

2. «**IP MODE**» 1–2 jumper position. This mode is aimed at operation in networks with IP-address dynamic allocation. At that the controller gets the IP-address (gateway, subnet mask) from DHCP-network server.

3. «**IP DEFAULT**» 2–3 jumper position.

- The controller operates with initial settings. IP-address and MAC-address are stated in the IP-Stile certificate and on the controller board; subnet mask 255.0.0.0; gateway IP-address 0.0.0.0.
- Controller access password is cleared.
- IP-address user settings (gateway, subnet mask) are saved (in case they were set). At the next powering, if the jumper is removed, the controller will be operating with these settings.

## 5.6 Firmware update

Use the «*Firming*» program to update the firmware and to format the **PERCo-Web** system controller memory.

## 6 MARKING AND PACKAGING

The IP-Stile has a marking label – inside, on the rear side of the housing and a sticker with connection layout on the internal side of the top cover. The marking contains the product name, the model abbreviation, the date of manufacture, the serial number and technical characteristics.

When it is necessary to access the label, remove the top cover (3) taking the following steps:

1. Turn IP-Stile power off.
2. Insert the key into the top cover lock (4), turn it clockwise until stop and open the lock (the lock internal mechanism will move out together with the latch).
3. Holding the back edge of the cover with one hand, lift the front edge gently by another – the cover must turn relative to the inside hooks. Remove the cover carefully making sure not to damage the controller underneath.
4. Lay the cover on an even steady surface.

Make sure the cover is returned in its operative position observing all the mentioned precautions. When the cover is on, close the cover lock pressing on the internal mechanism and recessing it into the housing until it clicks. Turn the power on for IP-Stile to continue operation.

IP-Stile standard delivery set (ref. section 4.1) is packed in a transportation box for protection against damage during transportation and storage.

Box overall dimensions (LxWxH) ..... 112x75x35 cm  
Maximum gross weight of the boxed IP-Stile (standard delivery set) ..... 56 kg

## 7 SAFETY REQUIREMENTS

### 7.1 Installation safety

Proper installation is critical to performance and serviceability of the product. We strongly advise to thoroughly study this section before beginning the installation work as well as observe general electrical and work safety rules during the installation.



#### ***Attention!***

- All work should be carried out only when the power is off and power supply is disconnected from the mains.
- Use only serviceable tools.
- Be extra careful and cautious when mounting the housing before it is anchored to the floor; make sure the housing does not fall.
- Cables should be laid in accordance with electrical safety requirements.
- Check the installation and connections accuracy before the first power-up.

Power supply installation must be carried out according to safety requirements given in its in-line documentation.

### 7.2 Safety during operation

Always observe general electrical safety rules when operating the product.



#### ***DON'T use!***

- When operation conditions don't conform to those given in the section 2.
- When the supply voltage differs from that given in the section 3.

The power supply operation should be carried out according to safety requirements in its in-line documentation.

## 8 INSTALLATION INSTRUCTIONS

Follow the safety requirements during the installation (see Clause 7.1).

### 8.1 Installation details

Correct turnstile installation provides its functionality and lifetime. Please carefully study and follow the installation instructions.

**It is recommended:**

- to mount the turnstile on steady and level concrete (grade 400 or higher), stone or similar foundations at least 150mm thick;
- to level the foundation so that the anchoring points of the turnstile lie in the same plane;
- to apply reinforcing elements (400×400×300mm) for installation on less steady foundation (frame foundation, for example).

To ensure accurate passage tracking, when the turnstile is operated from an ACS, it is recommended to create the passage area in such a way that the barrier arms should turn in the direction of movement at the angle no less than 70° (Figure 9).

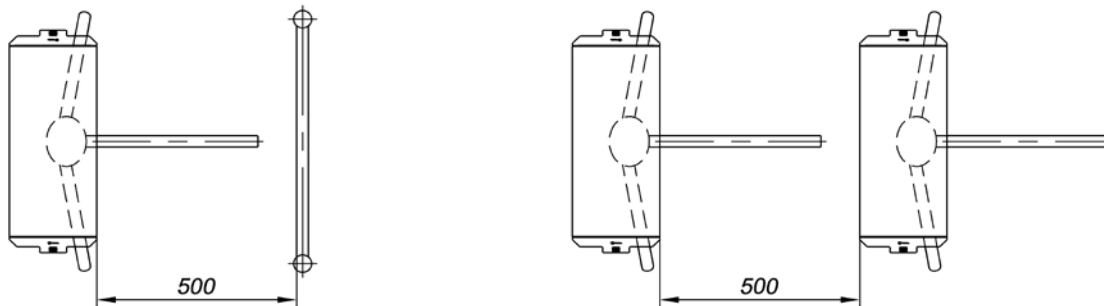

**Figure 9. Recommended passageway arrangements**

The turnstile is equipped with the resetting device that operates as follows:

- at the barrier arm turning at the angle of more than  $60^{\circ} \pm 5^{\circ}$  the reset is effected in the direction of movement and the turn of barrier arm to counter direction is not possible (blocking of return passage) ;
- at the barrier arm turning at the angle less than  $60^{\circ} \pm 5^{\circ}$  the reset is effected in the counter to the movement direction (reset to home position).

When planning the passage area it is necessary to arrange additional emergency exit. For example it can be the automatic rotary section BH-02 (Clause 10).

### 8.2 Tools and equipment required for installation

- 1.2÷1.5 kW hammer drill;
- Ø16 mm carbide drill bits for anchoring;
- Floor chaser to make cable-channels;
- Phillips head screwdriver №2;
- Straight-slot screwdriver №5, 150 mm long;
- S=17, S=13, S=10, S=8, S=7 horn and hex-nut wrenches;
- Plumb-line and level;
- Measuring tape 2 m.



**Note:**

Similar tools with the same characteristics can be used as long as proper installation work can be carried out.

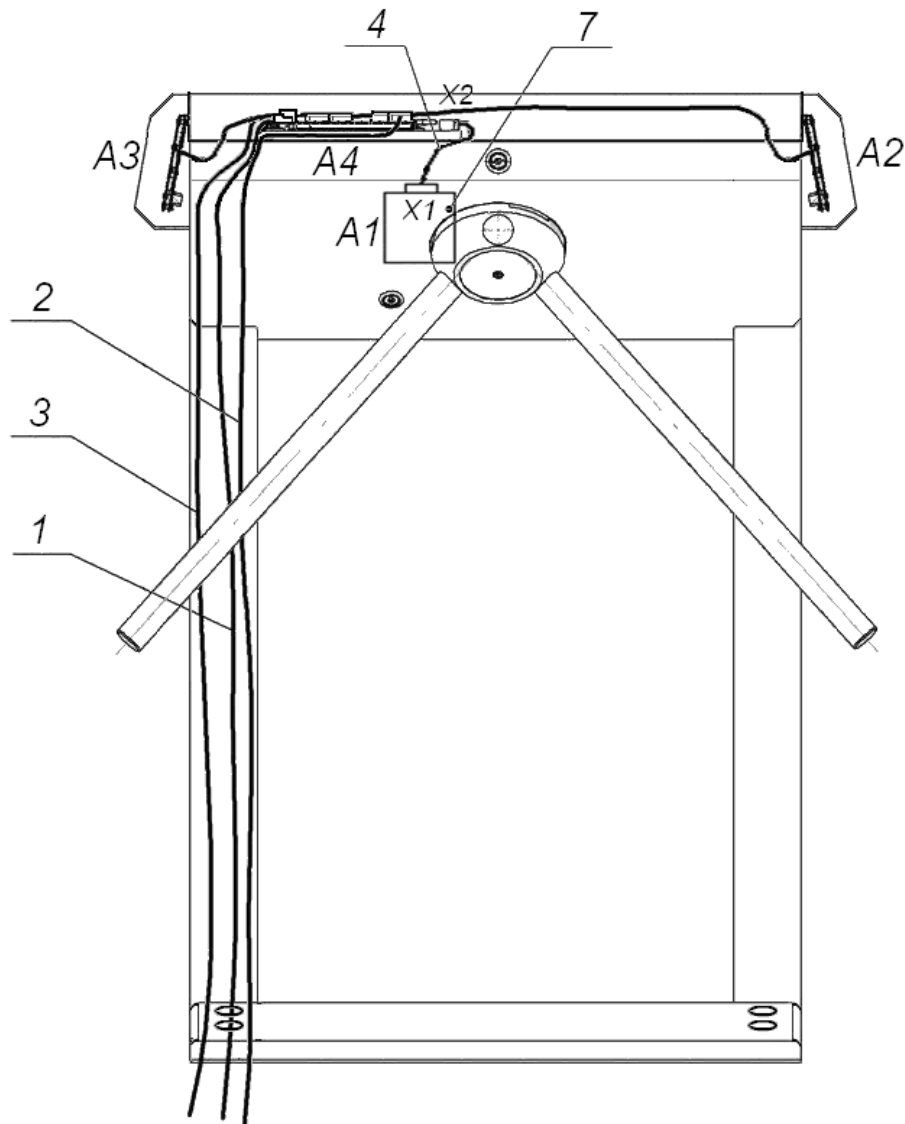

*Turnstile housing without cover  
(the internal mechanism)*

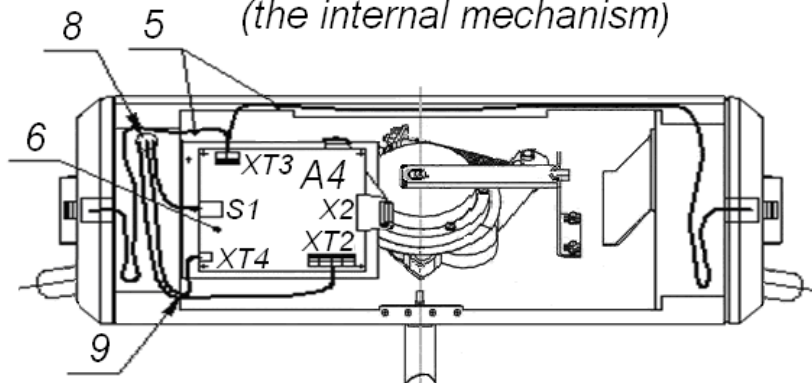

**Figure 10. Cable layout inside the housing**

- 1 – power cable; 2 – RC panel / WRC;
  - 3 – LAN cable (through Ethernet IEEE 802.3); 4 – turnstile cable;
  - 5 – readers connecting cables; 6 – **CT-03** board; 7 – operating mechanism;
  - 8 – opening for running the cables 1-3; 9 – opening for running the cables 1-2;
- (during installation of IP-Stile, the openings 8 and 9 are sealed with the insulation bushings); referred to as A1-A4 in Figure 12

### 8.3 Cable lengths

Cables, applied at the installation are stated in Table 4. During cable laying follow these instructions:

- Communication line assembly is to correspond to the *EIA/TIA RS-422A/485* standard recommendations.
- Minimum cable laying distance from the EMI source is 50 cm.
- All cables can cross the power cable only at a right angle.
- Cable growth is to be performed with the reflow technique.
- All the IP-Stile controller cables are to be fixed with plastic cable ties to the adhesive platforms from the delivery set inside the IP-Stile housing.
- After cable laying check the cable continuity and lack of short circuits.
- Grounding conductor shall not be laid together with the power cables, sensor, RC-panel and reader cables on the piece of land of more than 1 m.



#### Note:

The EMI is an undesirable effect of electromagnetic fields, interfering with the normal operation of the techniques or causing the malfunction of the technical characteristics and the parameters of these techniques. The sources of electromagnetic interferences are:

- readers,
- AC line,
- electric generator,
- electric motor,
- AC relay,
- thyristor light regulator,
- PC displays,
- Computer and telephone signal communication lines.

**Table 4. Cables used during the installation**

No	Equipment connected to the IP-Stile controller	Maximum cable length, m	Cable type	Minimum cross-section, mm	Example of the cable
1	Ethernet (IEEE 802.3)	100	Four twisted pair cables Cat5	0.2	Belden 1868E 2x2x0.52 F/UTP2-Cat5e
2	<b>AU-05</b> system time display.	1200 (total)	Twisted pair cable not less than Cat5		
3	Power supply	10	Twin wire	0.75	AWG 18; HO3VV-F 2x0.75 bi-coloured
		30	Twin wire	1.5	AWG 16; HO5VV-F 2x1.5 bi-coloured
4	- ID - Siren - <i>Fire Alarm</i> - Additional equipment for controller inputs and outputs	30	Twin wire	0.2	RAMCRO SS22AF-T 2x0.22 CQR-2
5	RC-panel	40	8 triad cable	0.2	CQR CABS8 8x0.22c
6	WRC	40	6 triad cable	0.2	CQR CABS6 6x0.22c

## 8.4 Installation sequence



### **Attention!**

The manufacturer will not accept liability for any damage or otherwise loss resulting of improper installation, and will dismiss any claims by the customer should the installation be not carried out in strict accordance with this Manual.

The connector block position on the IP-Stile controller board is shown on Figure 5. Connector block layout is shown in Table 1. Connection layout is shown Figure 12. Types of cables are stated in Table 4. Follow this sequence during reader installation:

1. Choose the place for IP-Stile installation and prepare the installation surface according to Section 8.1.
2. Unpack the box with equipment; check carefully the delivery set according to Section 4.
3. Mount the IP-Stile power supply according to instructions in its operation documentation.
4. Mark and prepare mounting holes for anchor bolt sleeves on the installation surface according to Figure 11.

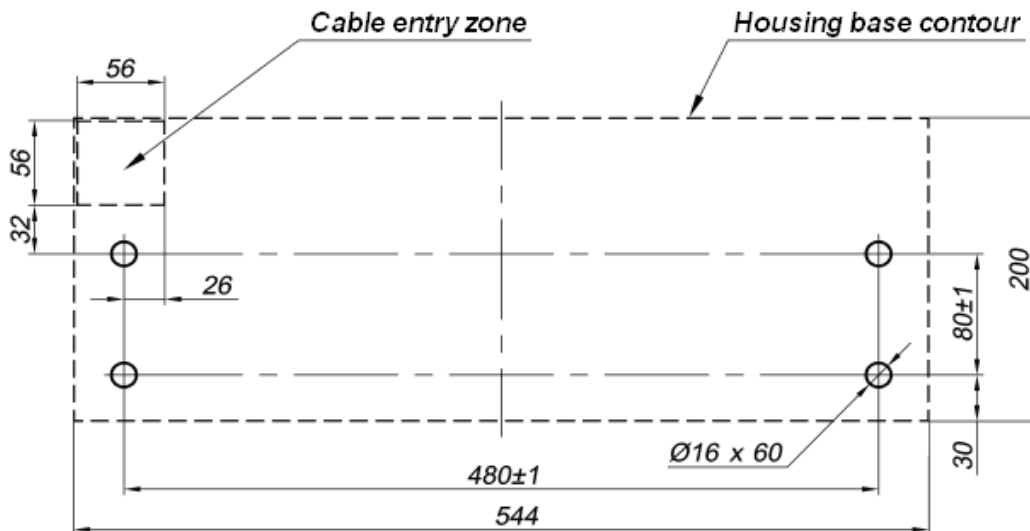

**Figure 11. Hole pattern for mounting of the housing**

5. Insert the anchor bolt sleeves in the holes so that they do not project above the surface of the floor.
6. Prepare the underfloor raceway matching the feed-through hole in the IP-Stile housing, in case it is needed.
7. Lay the cables (RC-panel, power, grounding, *Ethernet* cables) in the electrical conduit and pull the cables and perform cable lead-in in the IP-Stile housing through the required holes in the IP-Stile foundation.
8. Set up the housing on anchor bolt sleeves and fix it with the M10 bolts.
9. Open the housing top cover (3) with the key (4).The sequence of top cover opening is described in Section 6.
10. Pull the cables inside the housing. Recommended cable layout inside the post is shown on Figure 10.
11. Connect the power cable (12) to the **XT4** connector block on the controller board. Connect the cable of the RC-panel (10) to the **XT2** connector block as per Figure 12. If necessary, connect cables of other devices to the corresponding connector blocks.

12. Perform the IP-Stile housing grounding. Ground contact **Z3** is under the top cover (3) to the left of the controller board. In order to fix the grounding cable on the contact use M4 screw.



**Note:**

Connection scheme for the power supply of the controller and the turnstile when connected via PoE-splitter is shown in Figure 15 in Appendix 2.

13. Connect *Ethernet* cable to **S1** connector on IP-Stile controller board.
14. Fix all the cables inside IP-Stile housing with plastic cable ties to the adhesive platforms from the delivery set.
15. Insert back the top cover (3) in reverse order (Section 6).
16. For installation of the barrier arms into operational position, first unscrew the M4×25 bolt and take the cover (6) off the rotation mechanism. Unscrew the M8×30 bolts on the barrier arms (5). Install the barrier arm into the corresponding slots and fix it using the bolts with spring washers. Make sure the bolts are tightened enough to provide secure fixing of the barrier arm. Repeat this sequence to install other barrier arms.
17. Carry out a test power-up of the IP-Stile according to the Section 9.1. When the installation is completed, the IP-Stile is ready for operation.

**Table 5. The components list of the connection layout for IP-Stile and optional equipment**

Legend	Item	Qty
A1	Operating mechanism	1
A2	Reader №1	1
A3	Reader №2	1
A4	Controller <b>CT-03</b>	1
A5*	Power supply	1
A6	RC-panel	1
A7*	WRC	1
A8*	Siren	1
A9*	Intrusion detector	1
1	Turnstile cable	1

- Not included in the standard delivery set.



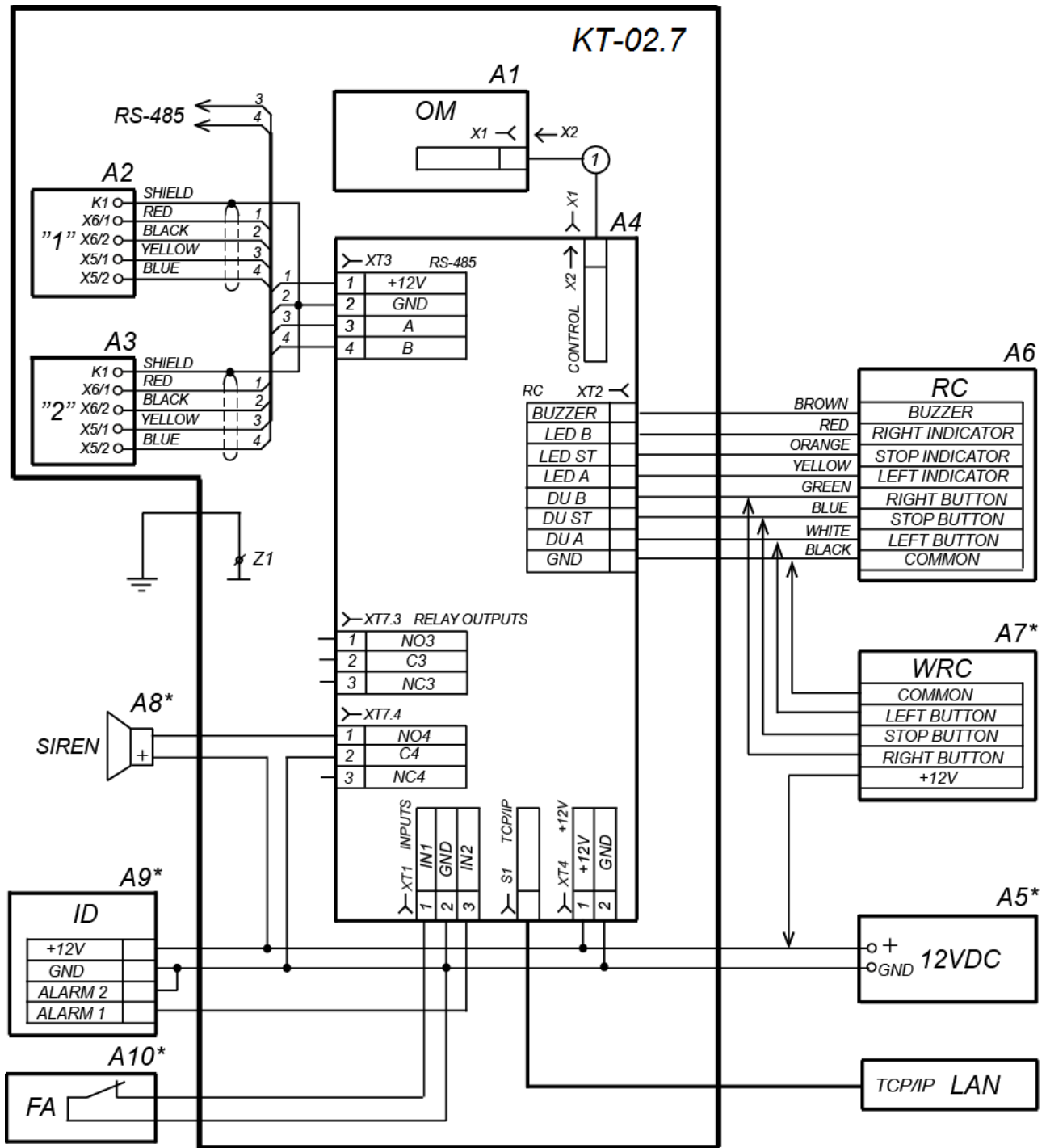

Figure 12. Connection layout for KT-02.7 and optional equipment <sup>1</sup>

<sup>1</sup> The components list of the connection layout for KT-02.7 and optional equipment see Table 5.

## 9 OPERATION

Operating the device observe safety requirements described in Section 7.2 «*Operation safety requirements*».



### **Attention!**

- Do not move through the IP-Stile passage area any objects with dimensions exceeding the width of the passageway.
- Do not jerk and hit any elements of the IP-Stile so as to prevent their mechanical deformation.
- Do not dismantle or adjust mechanisms ensuring operation of the IP-Stile.
- Do not use substances that may cause mechanical damage or corrosion of the surfaces for cleaning the IP-Stile.

### 9.1 Power-up

At IP-Stile power-up follow this sequence of actions:

1. Make sure all connections are correct (as per Section 8.4).
2. Make sure the barrier arms are in the home position (the passageway is blocked with a barrier arm).
3. Make sure the mechanical release lock is closed (the IP-Stile is mechanically locked, Ref. Section 10.2).
4. Connect the power supply to the mains with electric parameters as per its documentation.
5. Turn the power on.



### **Attention!**

When the controller configuration is changed with the jumpers, the controller internal memory is automatically formatted. This procedure lasts for about 2 minutes. After that the IP-Stile configuration should be transmitted to the controller by the Soft or Web-interface.

6. At the first powering the «*Control*» ACM is set for both directions. Yellow indicators (middle ones) of the indication modules are on and the red “*Stop*” indicator above the middle button on the RC-panel is on. Both passage directions are blocked.
7. If the formatting has not been performed, the ACM and the indication, set for each passage direction before power failure, is saved.
8. The IP-Stile is ready for operation right after the power-up. The operator can send command for locking/unlocking of both passages from the RC-panel. In order to arrange passage with proximity cards the additional configuration is to be used (Section 9.2).
9. In case ID and the siren are installed, check their operation. In order to do that wait until the test indicator inside ID fades (10–50 sec. after IP-Stile power-up). Bring your hand to the ID. In case it gets activated, there goes a constant audio signal. The signal will be off in 5 sec. It can also be deactivated by pressing any button on the RC-panel.

### 9.2 Configuration

The IP-Stile can be operated right after the installation performance and the power-up, without any additional configuration. At that the access control through IP-Stile is performed by the operator with the RC-panel, which is included in the standard delivery set, or with an optional WRC.

In order to provide access with proximity cards, send the cards identifiers to the IP-Stile controller memory. This can be performed from the PC, connected to the IP-Stile or through the *Ethernet*.

To connect to the IP-Stile controller through the *Ethernet* network, make sure the PC is in one subnet with the controller.

At the production stage the controller is assigned a unique physical address (MAC-address) and IP-address (given in the label of the processor microchip), the subnet mask (255.0.0.0) and IP-address of the gateway (10.x.x.x). The IP-Stile controller is to be connected to the same network segment or to the network card slot of the PC.

When operation commands are simultaneously sent from several devices, they will be executed in the following order:

- IP-Stile reader command,
- PC or Web-interface command,
- RC-panel or WRC command

### 9.3 IP-Stile control orders from the RC-panel



#### **Attention!**

Set the “Control” ACM to operate the IP-Stile from the RC-panel or the WRC.

The passage directions are independent of each other, i.e. setting an operating mode in one direction will not change an already set operating mode to another.

Setting of the operating modes by the RC-panel / WRC and the corresponding indication is given in Table 6. Please kindly note that:

- At first powering the «Control» ACM is set for both directions. Both passage directions are blocked.
- For «*Single passage in the set direction*» mode. IP-Stile locks automatically after passage completion in the set direction or in case the passage has not been completed within the **Holding in unlocked state** timing. The initial setting of this timing is 4 seconds and it does not depend on the control impulse length. The time of holding in unlocked state is counted from the moment when the command from the RC-panel or the WRC is received.
- The «*Single passage in the set direction*» mode can be changed to the «*Free passage in the set direction*» or «*Always locked*» mode.
- The «*Free passage in the set direction*» can be changed only to «*Always locked*» mode.
- For «*Bidirectional single passage*». After the passage completion in one direction the **Holding in unlocked state** timing countdown for another direction begins.

### 9.4 Operation as a part of an ACS

ACM change is performed at the command from the PC or Web-interface independently for each passage direction. The controller, as an element of the ACS, provides ACM through the turnstile (lock) (ACM indication is stated in Table 7):

ACM «Open» – free passage mode.

- The turnstile (lock) is unlocked until the ACM change.
- Pressing the RC-panel buttons and WRC button («Exit») is ignored.

ACM «Control» – main operation mode as a part of ACS.

- The turnstile (lock) is blocked.
- If the presented card matches the criteria of access granting, the turnstile (lock) is unlocked for **Holding in unlocked state time**.

Table 6. IP-Stile Operating Modes

No	Operating mode	Sequence of buttons to push	RC indication	Turnstile indication	IP-Stile status
1	<b>«Always locked»</b> (IP-Stile is closed for both entrance and exit)	Press the Stop button shortly	The red indicator is on	The amber indicators for both directions are on	The barrier arms are locked in the home position. The passageway is blocked by the barrier arm.
2	<b>«Single passage in the set direction»</b> (IP-Stile is open for a single passage by one person in the set direction and closed for passage in another direction)	Press shortly the Go button responsible for the authorized direction	The green indicator above the Go button responsible for the authorized direction is on	The green indicator for the authorized direction and the amber indicator for another direction are on	The barrier arms are unlocked for a single turn in the authorized direction. After the turn the arms are locked.
3	<b>«Bidirectional single passage»</b> (IP-Stile is open for a single passage in each direction)	Press both Go buttons together shortly	Both green indicators are on	The green indicators for both directions are on	The barrier arms are unlocked for consecutive single turns in each authorized direction. After each turn the arms are locked in the corresponding direction.
4	<b>«Free passage in the set direction»</b> (IP-Stile is open for free passage in the authorized direction and closed in another)	Press shortly the Stop button together with the Go button responsible for the authorized direction	The green indicator above the Go button responsible for the authorized direction is on	The green indicator for the authorized direction and the amber indicator for another direction are on	The barrier arms are unlocked indefinitely for multiple turns in the authorized direction
5	<b>«Free passage in the set direction and a single passage in the opposite direction»</b> (IP-Stile is open for free passage in the authorized direction and a single passage in another)	Press shortly the Stop button together with the Go button responsible for the free passage direction; then press the other Go button shortly	Both green indicators are on		The barrier arms are unlocked indefinitely for multiple turns in the free passage direction and a single turn in the single passage direction
6	<b>«Free passage in both directions»</b> (IP-Stile is open for free passage in both directions)	Press shortly the three buttons together	Both green indicators are on	The green indicators for both directions are on	The barrier arms are unlocked indefinitely for multiple turns in both directions

ACM «*Closed*» – locked mode.

- The turnstile (lock) is locked until the ACM change.
- RC-panel and remote control commands («*Exit*») are ignored.
- Any card presentation is registered as the access violation.

## 9.5 Access control mode, indication of controller events and states

IP-Style controller indication is displayed on the indication blocks (Section 5.2.2).



**Note:**

- When reading the proximity card identifier in any ACM, the audio signal of 0.5 sec. is sent, the yellow light indicator changes its status for 0.5 sec. Other identifiers don't change their status.
- If the access with the proximity card is granted, the light indication is turned to **Holding in unlocked state time**, or until the moment of the next passage. If the access is banned, the indication is turned on for 2 seconds.

Possible indication variants are stated in Table. 7.

**Table 7. Controller indication**

Card presentation	ACM	Indicators			
		Green	Yellow	Red	Sound (sec.)
No configuration	No	5 Hz	5 Hz	5 Hz	off
No	« <i>Open</i> »	on	off	off	off
	« <i>Control</i> »	off	on	off	off
	« <i>Closed</i> »	off	off	on	off
Access denied	« <i>Open</i> »	on	off	off	0,5
	« <i>Control</i> »	off	off	on	1
Any card	« <i>Closed</i> »	off	off	on	1
Access granted	« <i>Open</i> »	on	off	off	0,5
	« <i>Control</i> »	on	off	off	0,5
Waiting for verification/ double-check access	Any	off	2Hz	off	0,5

## 10 EMERGENCY ACTIONS



### **Attention!**

For a fast safe escape from the facilities in case of fire, natural disaster or other emergencies, an emergency exit is often required. Such an exit can be arranged by means of the **PERCo-BH02** anti-panic hinged sections.

### 10.1 Emergency exit by use of anti-panic barrier arms

An additional emergency exit can be arranged by means of anti-panic barrier arms. The design of the barrier arms enables arranging of a free escape passage without any special means or tools.

To make the passageway free, just pull the horizontal barrier arm along its axis outwards the hub until released, then fold the arm down (ref. Figure 13).

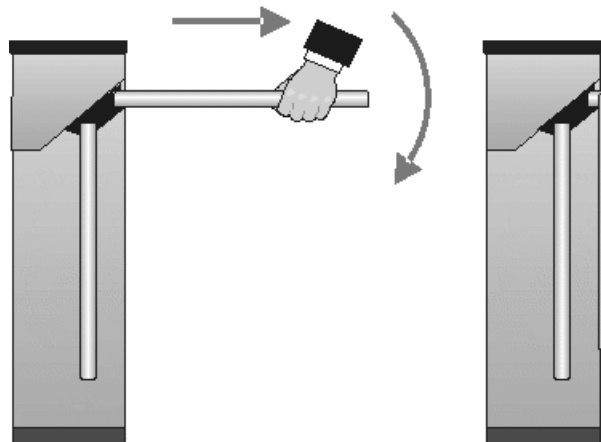

**Figure 13. Anti-panic barrier arms operation**

### 10.2 Mechanical unlocking

The mechanical unlocking feature is designed for unlocking the barrier arms in case of emergency, e.g. the power supply is down.

Proceed as follows to mechanically unlock the IP-Stile:

1. Insert the key into the mechanical release lock (7) and turn the key clockwise until it stops.
2. Make sure the IP-Stile is unlocked by rotating the barrier arms a few turns in each direction.

To lock the IP-Stile mechanically:

1. Set the barrier arms in home position;
2. Press the internal lock mechanism recessing it into the housing until it clicks;
3. Make sure the IP-Stile is locked and the barrier arms cannot be rotated in either direction.

### 10.3 IP-Stile automatic unlocking

Operating as a part of **PERCo-Web**, in case the fire breaks out or in any other emergency situation, the IP-Stile can be turned to *Fire Alarm* mode by the emergency unlocking device. In this mode the IP-Stile unlocks for passage in both directions. Other commands at this mode are ignored (Section 5.4.1).

## 11 TROUBLESHOOTING

Possible faults to be corrected by the customer themselves are given below. Contact the manufacturer if other fault or malfunction occurs. In order to perform the diagnostics, remove the IP-Stile top cover (3) in accordance with Section 6.

### 11.1 IP-Stile controller is not working

Testing of the relay outputs is assisted by test of the LEDs beside each of the relays. Activation / release of the relay is evident by the LEDs going on/ off.

Possible causes of the controller malfunction are as follows:

- Power supply malfunction – check the power supply.
- Loose cable fixing in the connector blocks on the controller board – tighten the cable fixing bolt with a screwdriver.
- Faulty radio components on the controller board – the controller needs repair at the manufacturer's site.

Possible causes of malfunction of the equipment, connected to controller outputs.

- Loose cable fixing in the connector blocks on the controller board –tighten the cable fixing bolt with a screwdriver.
- Faulty controller connection lines of other devices (readers, the IP-Stile housing, RC-panel, WRC, siren, etc.) – make sure the connection lines are operable.
- Malfunction of the devices connected to the controller – make sure the connected devices are faultless.

### 11.2 IP-Stile controller is not recognized by the PC

Faults related to LAN equipment between the PC and the controller (the hub, the switch and other network apparatus including the communication cables) can be determined by running the command ping 10.x.x.x (where 10.x.x.x is IP-address of the controller). If this command fails, the fault must relate to either the network settings or the connecting LAN apparatus including the communication cables, or to the controller.

Faults related to the controller (malfunction of the elements providing connection through the *Ethernet* interface (IEEE 802.3)). To determine this fault, observe operation of two indicators near the LAN connection point (to do so remove the cover off the IP-Stile):

LINK – connection evidence (the green indicator on – the controller recognizes the LAN connection, the green indicator is off – the controller does not recognize the LAN connection);

ACT– data exchange evidence (the red indicator blinking – the controller recognizes data exchange through the LAN, the red indicator off – the controller does not recognize data exchange through the LAN).

If the controller does not recognize the LAN connection, connect it to the cable of another controller or a PC. If the controller still does not recognize the LAN connection, the controller is faulty and must be sent for repair.

## 12 MAINTENANCE

Normally, only yearly operational maintenance is required. In an unlikely event of malfunction, maintenance should be carried out upon fault elimination. Maintenance must be undertaken only by a qualified technician well acquainted with this Manual.

The operational maintenance sequence is as follows:

1. turn off the power;
2. remove the cover (3) as described in section 6;
3. Lay the cover on an even steady surface;
4. inspect the resetting device (the pusher, the springs and the roller), the optical rotation sensors for the barrier arms and the damper (ref. Figure 14);
5. using a clean rag soaked with alcohol gasoline blend, remove dirt and stains, when necessary, from the arm rotation sensor disc; make sure the dirt does not get into the operating clearances of the optical;
6. lubricate the following parts with machine oil:
  - four bushes of the resetting device (two on the rotation axis of the pusher and two on the fastening axis of the spring), as well as the holes in the fastening parts of the springs: two-three oil drops into each lubrication point (the lubrication points are shown in Figure 14);



### **Attention!**

Avoid ingress of the lubricant on the arm rotation sensor disc and the roller surfaces.

- the internal mechanisms of the mechanical release lock's (7) and top cover's (4) through the keyholes;
  7. check the reliability of the cable connections to the connector blocks of the **CT-03** controller board, tighten the fixing bolts when necessary;
  8. make sure the barrier arms (5) are secure in place, proceeding as follows::
  9. unscrew the M4×25 bolt fixing the cover (6) and remove it;
  10. if necessary, tighten the M8×30 bolts fixing the barrier arms with S13 wrench;
  11. return the cover in the operational position and fix it with the bolt;
  12. Cap the four anchor openings in the housing base (2) and if the auxiliary opening for cable connection in the case (1) lower part (if not used) with the Ø30 mm plugs included in the delivery set. remove the plugs from the anchor openings in the housing base, check the anchor bolts tightening them if necessary with S17 wrench; return the plugs back on the anchor openings;
  13. return the top cover (3) in its operational position (ref. section 6), do not apply much force in doing this; the top cover lock is closed by pressing the lock internal mechanism without turning the key;
  14. test IP-Stile operation according to section 9 of this Manual.

After completion of maintenance work and testing IP-Stile is available for further use/

If during the operational maintenance some IP-Stile components are found defective, or after the expiration of the warranty period (ref. IP-Stile Certificate), we recommend to contact PERCo for advice and closer inspection of IP-Stile components.



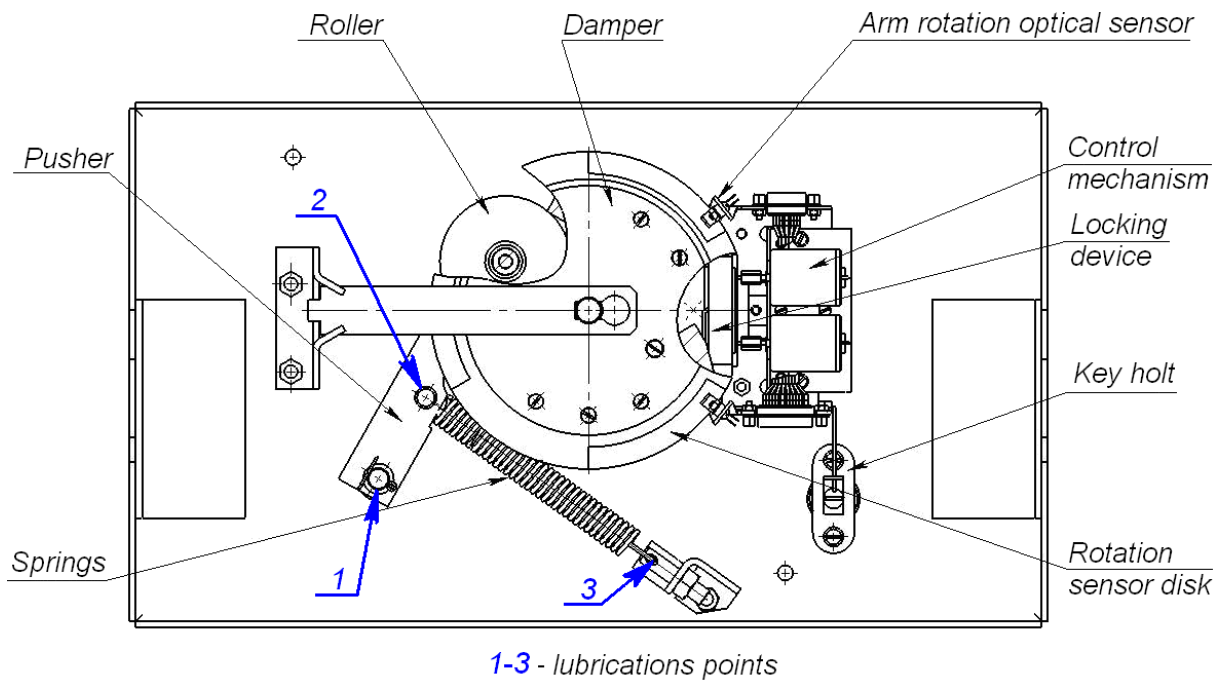

**Figure 14. Arrangement of the components inside the IP-Stile housing**

### 13 TRANSPORTATION AND STORAGE

IP-Stile in the original package should be transported in closed freight containers or other closed type cargo transport units.

During storage and transportation the boxes can be stacked no more than 4 layers high.

The storage of the product is allowed indoors at ambient temperature from  $-25^{\circ}\text{C}$  to  $+40^{\circ}\text{C}$  and relative air humidity up to 80% at  $+25^{\circ}\text{C}$ .

After transportation or storage at temperatures below zero or in high air humidity, prior to the installation the product must be kept unpacked for no less than 24 hours indoors in the climate conditions as per given in section 2).

## Appendix 1. Algorithm of control signals generation during standalone operation

Input of a low-level signal relative to the *GND* contact at the contacts *DUA*, *DUS<sub>t</sub>* and *DUB* of the connector block *XT2* can generate the following commands:



### Note:

- The command is the falling edge of the signal at any of the contacts while the corresponding signal levels are present at the other contacts.
- The falling edge of the signal – when the signal level changes from high to low.

**Always locked (IP-Stile is locked for both entry and exit)** - the falling edge at the contact *DUS<sub>t</sub>* with the high signal level at the contacts *DUA* and *DUB*. This command closes both directions

**Single passage in the direction A (IP-Stile is open for passage of one person in the direction a)** - the falling edge at the contact *DUA* with the high signal level at the contacts *DUS<sub>t</sub>*, *DUB*. This command opens the direction A either for the passage waiting time or until the passage in this direction is completed, or until the «**Always locked**» command is given, while the direction B mode remains unchanged. The command is ignored if at the moment of its receipt the direction A is in the «**Free passage**» mode.

**Single passage in the direction B (IP-Stile is open for passage by one person in the direction B)** - the falling edge at the contact *DUB* with the high signal level at the contacts *DUS<sub>t</sub>*, *DUA*. This command opens the direction B either for the passage waiting time or until the passage in this direction is completed, or until the «**Always locked**» command is given, while the direction A mode remains unchanged. The command is ignored if at the moment of its receipt the direction B is in the «**Free passage**» mode.

**Bidirectional single passage (IP-Stile is open for one passage in each direction)** - the falling edge at the contact *DUA* with the low signal level at the contact *DUB* and high level at the contact *DUS<sub>t</sub>* or the falling edge at the contact *DUB* with the low signal level at the contact *DUA* and high level at the contact *DUS<sub>t</sub>*. This command opens both directions, each for the passage waiting time or until the passage in this direction is completed, or until the «**Always locked**» command is given. The command is ignored for the direction which at the moment of its receipt is the «**Free passage**» mode.

**Free passage in the direction A (IP-Stile is open for free passage in the direction A)** - the falling edge at the contact *DUA* with the low signal level at the contact *DUS<sub>t</sub>* and high level at the contact *DUB* or the falling edge at the contact *DUS<sub>t</sub>* with the low signal level at the contact *DUA* and high level at the contact *DUB*. This command opens the direction A until the command «**Always locked**» is given, while the direction B remains unchanged.

**Free passage in the direction B (IP-Stile is open for free passage in the direction B)** - the falling edge at the contact *DUB* with the low signal level at the contact *DUS<sub>t</sub>* and the high signal level *DUA* or the falling edge at the contact *DUS<sub>t</sub>* with the low signal level at the contact *DUB* and high level at the contact *DUA*. This command opens the direction B until the command «**Always locked**» is given while the direction A remains unchanged.

**Free passage (IP-Stile is open for free passage in both directions)** - the falling edge at the contact *DUA* with the low signal level at the contacts *DUB*, *DUS<sub>t</sub>*, or the falling edge at the contact *DUB* with the low signal level at the contacts *DUA*, *DUS<sub>t</sub>*, or the falling edge at the contact *DUS<sub>t</sub>* with the low signal level at the contacts *DUA*, *DUB*. This command opens both directions until the command «**Always locked**» is given.



**Note - for the RC-panel:**

- the falling edge — the moment the corresponding RC-panel button is pressed;;
- the low signal level— the corresponding RC-panel button is pressed.
- the high signal level— the corresponding RC-panel button is not pressed.

## Appendix 2. Connection through PoE-splitter



**Attention!**

- The given instructions are given for the splitters, included in the optional delivery set.
- Overall power consumption of the IP-Stile and all the equipment powered by it should not exceed 12 W. Leave excess powers of minimum 10%.

### Description of splitter

**PoE-splitter** (hereinafter – splitter) is designed for powering of devices connected to *Ethernet* network. Splitter works with any network switches (hereinafter – Switch), supporting the powering by PoE twisted pair and compatible with *IEEE 802.3af* standard.

Splitter features electronics module in a plastic case, it is equipped with following connectors:

- Con 1** – connector for *Ethernet* cable from *Switch*.
- Con 2** – connector for *Ethernet* cable from the device;
- Con 3** – connector for power cable.

### Requirements for connected devices

Power consumption characteristics of controller when connected through splitter shall correspond with the following requirements:

Allowable voltage of DC power .....	12±1.2 V
Minimum joint current of consumption .....	min. 120 mA
Maximum joint current of consumption (@ 12V) .....	max. 1 A
Maximum joint power consumption .....	max. 12 W

In order to prevent excess of joint power consumption it is not recommended to power additional equipment (siren, passage sensors etc.) and second level controllers by controller.

### Connection of IP-Stiles

Follow this order while connecting IP-Stile through the splitter:

1. Choose the mounting place. It is recommended to mount splitter inside the case of controller (The distance between controller and splitter shall not exceed 2 m).
2. Connect *Ethernet* cable from the controller to **Con2** connector.
3. Connect power supply circuit of controller and operating device, controlled by it, to **Con3** connector of splitter. Connection schemes are given on Figure 15. (connection plug is included into delivery set of splitter).
4. Connect *Ethernet* cable from Switch to **Con1** connector of splitter.
5. The connected device will be powered after the verification between Switch and splitter.

If you need to turn the power of controller off, disconnect *Ethernet* cable that goes from Switch, from **Con1** connector.

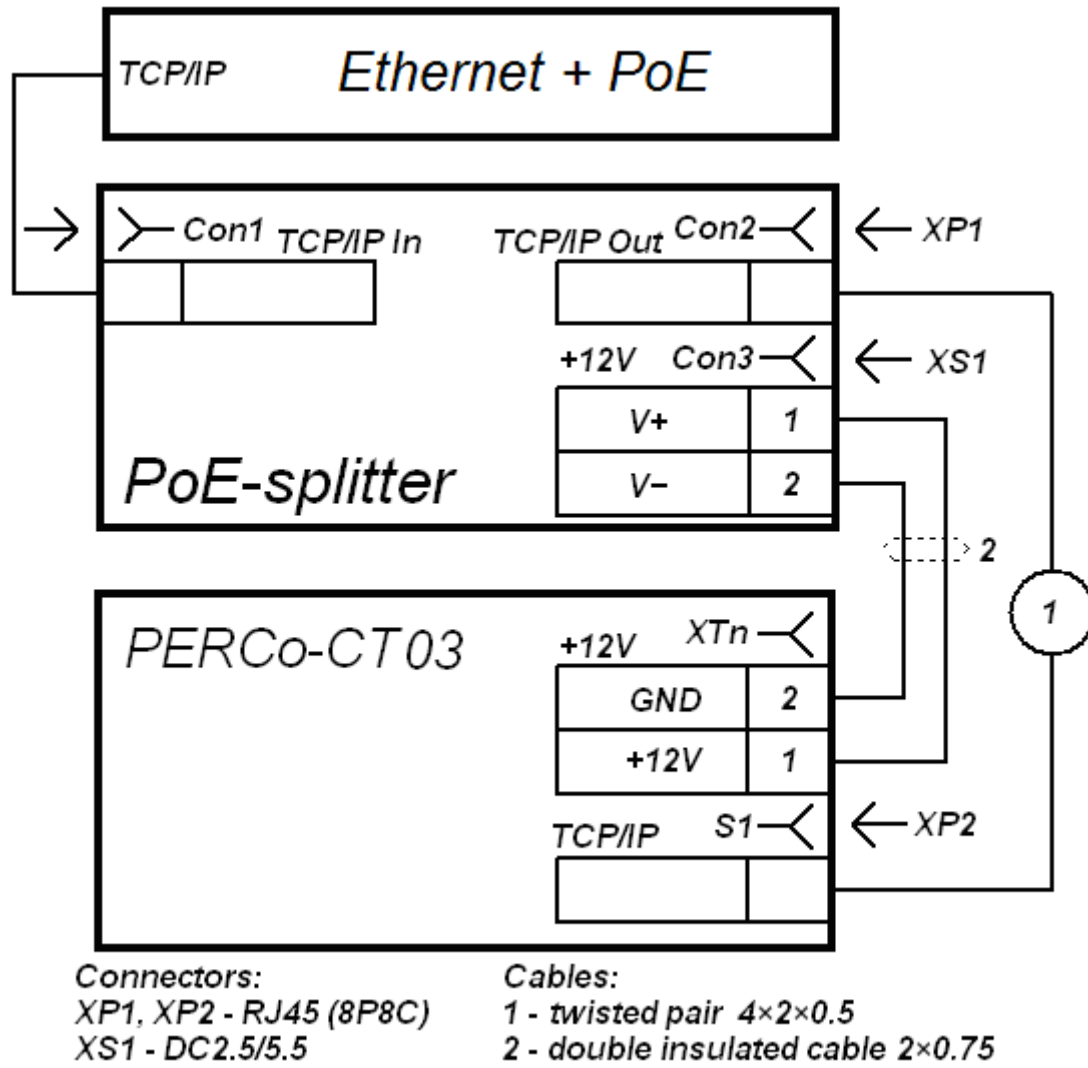

Figure 15. IP-Stile controller connection scheme

# **PERCo**

P.O. Box 87,  
Saint Petersburg, 194295,  
Russia

Tel: +7 812 321 61 72

Fax: +7 812 292 36 08

**E-mail: [export@perco.ru](mailto:export@perco.ru)  
[support@perco.ru](mailto:support@perco.ru)**

**[www.perco.com](http://www.perco.com)**



[www.perco.com](http://www.perco.com)  
[export@perco.ru](mailto:export@perco.ru)