

1. APPLICATION

LB-72.4 is a normally-opened electromechanical mortise door lock (hereinafter – the lock), designed to be used as an operating device as a part of access control system (hereinafter – ACS) to control light and medium office doors.

Lock features:

- the lock has installed in wooden and non-metallic doors 38-50 mm thick;
- the lock has a unique construction, allowing to connect lock control cable through the strike plate in the door frame, not through the door leaf, which makes installation easier;
- when connecting to "PERCo" ACS controllers, operation of the lock can be maintained without using a door sensor (reed switch), the contact group of the lock is used instead;
- automatic orientation of the contact group relatively of the locking bolt, implemented through the use of neodymium magnets, can significantly increase the tolerances during installation and the reliability of the lock;
- the lock design allows you to use almost all types of lever handles that are on the market;
- the lock is designed for use with standard lock cylinders;
- a universal lock construction enables its installation on both right-handed and left-handed doors;
- in the absence of supply voltage, the lock is not locked;
- with voltage applied the lock closes automatically at shutting the door;
- with voltage applied the lock can be open with the key;
- forend plate, strike plate and locking bolt made of stainless steel; details and lock body have corrosion-resistant coating;
- the lock is resistant to self-opening (for instance, as result of a hard kick on the door);
- the design of the lock does not require preventive maintenance and lubrication from the customer for the entire period of operation;
- the lock has low power consumption (max 2 W).

The lock with regard to resistance to environmental exposure complies with GOST 15150-69, category NF4 (operation in premises with climate control).

Operation of the lock is allowed at ambient air temperature from +1°C to +40°C and at relative air humidity of 75% at+15°C.

The lock has a marking in the form of label located on its housing. Label contains product name, its serial number, the manufacture date and its main technical specifications. The product is packed in a carton box, protecting it from being damaged during transportation and storage.

Box dimensions (L×W×H) 22×12×4 cm
Gross weight max. 0.9 kg

Lock storage is allowed indoors at ambient air temperature from -50°C to +50°C and at relative air humidity of 75% at+15°C. Storage time in closed package is 12 months.

During storage and transportation carrying cases containing boxes with locks can be stacked no more than 2 layers high.

The lock in the original package can be delivered by means of land (railway and road), sea and air transport. It is allowed to stack the boxes while in transit.

2. TECHNICAL SPECIFICATIONS

Attention!

Due to continuous improvement of products the Manufacturer reserves the right to modify, without notice, the product design not aggravating its technical specifications.

DC voltage	11 - 13V
Operational current	0.08 - 0.12A
Power consumption	max. 2W
Type (fail-safe performance)	normally-opened
Bolt throw	not less than 15 mm
Centre-to-centre spacing	72 mm
Backset (dormmass)	45 mm
The size of the square-hole for the lever rod	8 mm
Dimensions	94×22×172 mm
Weight	not more than 0.5 kg
Lock type	cylinder ¹
Resistance to opening	I (EN 12209)
Electric shock protection class	III (IEC 61140)
MTBF	200 000 number of operations
Average lifetime.....	8 years

Design and composition of the lock are shown in Fig. 1

3. STANDARD DELIVERY SET²

Attention!

Check the delivery set upon product receipt.

Lock	1
Strike plate	1
Terminal block	1
Lock cylinder fastening screw M5×50 DIN965	1
Screw 3×6 DIN965	2
Screw 3.9×25 DIN982	4
Mounting stud	5
Certificate and operation manual	1
Installation template	1
Package box	1

¹ The universal construction provides use of standard pin-type lock cylinders, standard EuroDIN (V DIN 18254), e.g. type 8809, 8209 produced by company ISEO (Italy), or lock cylinders of D series by Wilco Supply (type 254 – 274 – 294, 453, 454, 554).

² The lock cylinder with a set of keys, door levers with fixing elements, reed switch, control and reed switch cables are not included in the delivery set.

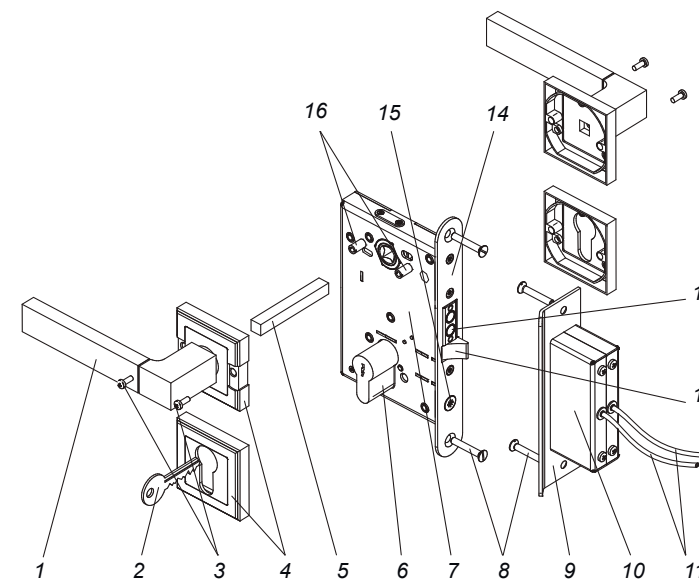
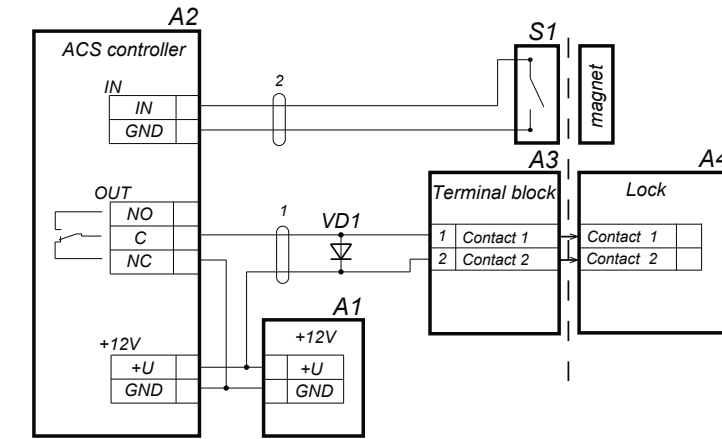

Fig.1. LB-72.4 electromechanical lock design

- 1- Lever³; 2 - Key³; 3 - Escutcheon plate fastening screw³;
4 - Escutcheon plate³; 5 - Lever rod³;
6 - Lock cylinder³; 7 - Lock; 8 - Screw 3.9×25;
9 - Strike plate; 10 - Terminal block; 11 - Terminal cables;
12 - Locking mechanism lever; 13 - Locking bolt; 14 - Forend plate;
15 - Lock cylinder fastening screw M5×50; 16 - Mounting studs

³ Not included in the delivery set



Position	Unit	Note
1	Control cable of the ACS controller	
2	Reed switch cable	
A1	Power supply unit	12V; 0.5A; 6W
A2	Lock controller	
A3	Terminal block	
A4	Lock	
S1	Reed switch	
VD1	Suppressor	15–18 V (BZW06-15B, P6KE16CA)

Fig. 3. LB-72.4 electromechanical lock layout

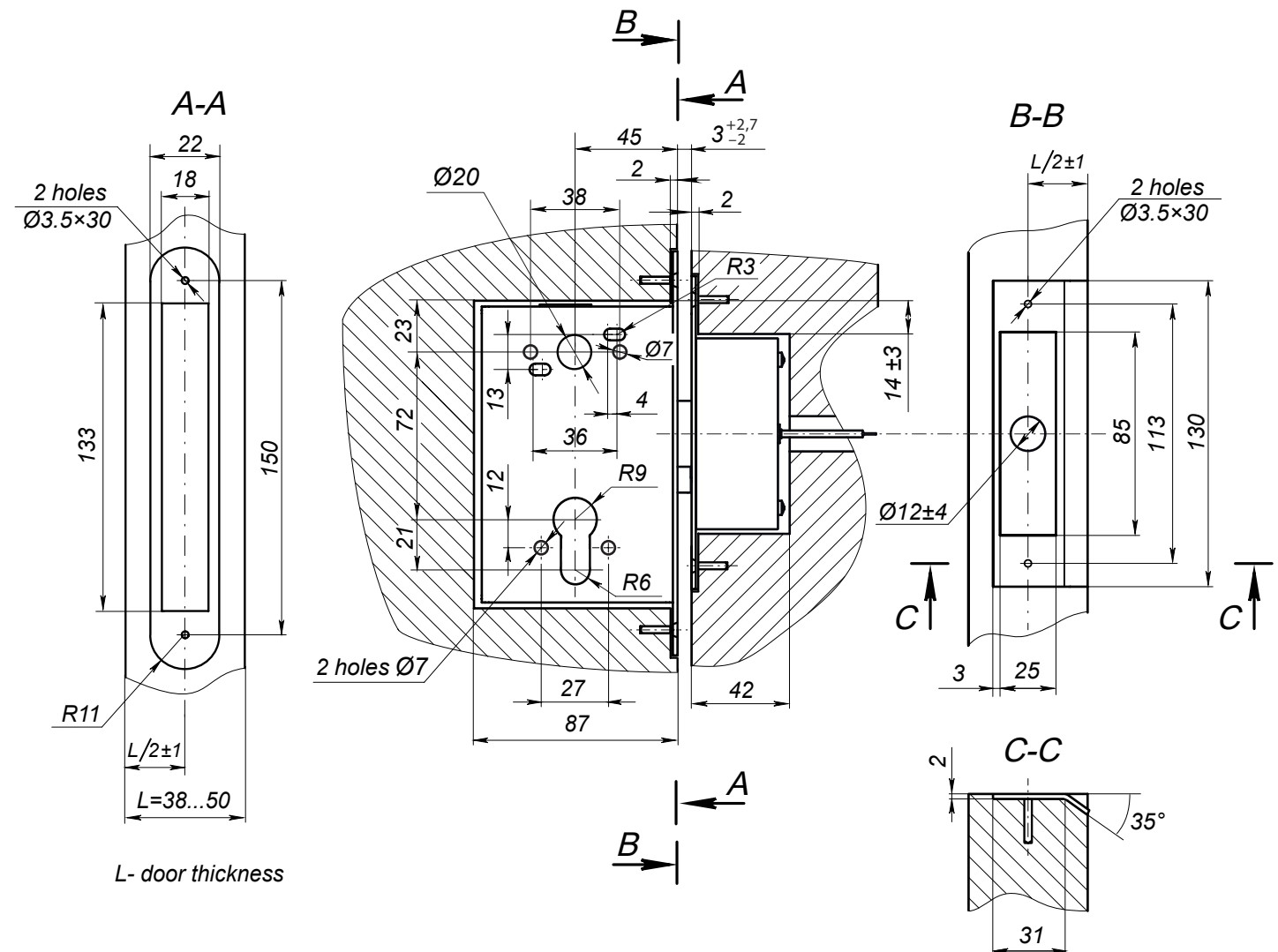

Fig. 2. Electromechanical lock installation layout

WARRANTY CARD

WARRANTY REPAIR COUPON

Cutting line

4. ASSEMBLY AND INSTALLATION

Attention!
In order to provide stable lock operation, it is necessary to ensure the accuracy of the installation of the strike plate with the terminal block relative to the locking bolt ± 3 mm vertically and ± 1 mm horizontally (see Fig. 2). The lock operates normally if the spacing between the forend plate and the strike plate is 1 ... 5.7 mm (recommended clearance of 3 mm).

Type and length of control cable used:

- twin cable with 0.75 mm cross-section (two-color HO3VV-F, HO5VV-F 2x0.75) - up to 30 meters long.

Install the lock in the following order (reference numbers are given in accordance with Figure 1):

1. Upon delivery, the locking mechanism lever is oriented for installation on the left door. In order to install the lock on the right door needs to change its position (see Fig. 4). For this:

- remove the forend plate by unscrewing the three fixing screws;
- remove the locking mechanism lever with the axle;
- turn the lever 180° and lower its axis;
- place the lever into place with the axle in the opposite slot;
- install the forend plate and secure it with screws

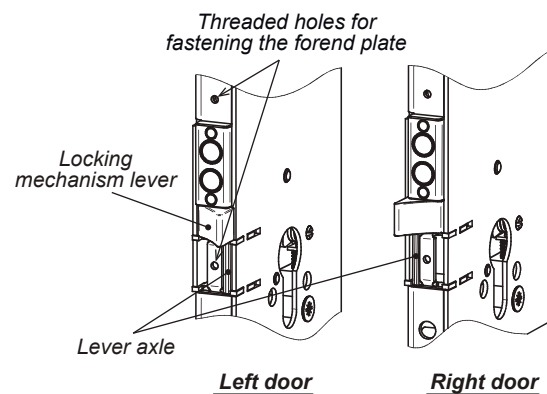

Fig. 4. Locking mechanism lever position on the left and right doors

2. Make the hole marking for lock cylinder (6), lever rod (5) and, if needed, of a location slot for lock forend plate (14) in the door leaf in the place of lock installation using the installation template from the delivery set. Template marking corresponds to the one in Fig. 2.
3. Carve out holes and choose the location slot for lock forend plate in accordance with the marking.
4. Install the lock (7) in the locating pocket of the door and fasten it with two screws 3.9x25 from the delivery set.
5. Mount the lock cylinder inside the lock and fix it with the screw supplied through the hole on the lock forend plate (this screw included in delivery set).
6. Adjust the door levers (1) with escutcheon plates (4) in accordance with manufacturer recommendations. If necessary for fastening overlays, use the mounting racks (16) supplied. After the installation levers are to turn easily.
7. Fix the strike plate (9) on the terminal block housing (10) with two screws 3x6 from the delivery set.
8. Mark out and carve into the door jamb installation groove for the strike plate with the terminal block (in accordance with Fig. 2). Use the installation template from the delivery set.
9. Lay the control cable from the ACS to the terminal block installation place inside the door frame. The cable laying method is determined by lock installer and the Customer.
10. Connect the control cable to the wires of the terminal block by soldering or use standard crimp lugs (terminals).

Attention!
If the lock is operated as a part of access control system (ACS) it is recommended to install voltage regulator diode BZW06-15B or P6KE16CA, or another model with equal parameters on contact clips (Fig. 3). The voltage regulator diode is used for maintaining the device which sends the control signal.

11. Mount the strike plate with the terminal block in the door frame providing 2-3 mm spacing between the strike plate and the forend when the door is closed. The channel of the strike plate must lay symmetrical to bolt's cross section.
12. Mount the strike plate on the door frame with two screws 3.9x25 from the delivery set.

Attention!
The locking mechanism lever should not get into the channel of the strike plate! Otherwise, at closing the door, it can get locked with the moving lever and then it will be impossible to open the door without damaging the lock.

13. If necessary, install and connect the reed switch. Installing the reed switch ensure firm contact closure at closing the door. In the PERCo ACS the role of the door sensor can be performed by the terminal block of the lock itself, in this case, the installation of the reed switch is not needed

14. Connect the lock and reed switch to ACS controller according to the scheme shown in Fig. 3.

15. Check the lock operation:

- At the opened door push in the locking mechanism lever (4) inside the lock housing. The locking bolt will move out of the lock housing (3). Holding the locking mechanism lever in a pressed position, turn the lever handle against stop. The locking bolt will return into the initial position inside the lock housing. Keeping the locking mechanism lever in a pressed position, leave the lock lever. The locking bolt will move out of the lock housing. Leave the locking mechanism lever. The locking bolt will return into the initial position inside the lock body.
- Close the door. Apply 12V voltage to the terminal block contacts, the lock will be closed automatically.
- Insert the key (14) inside the lock cylinder and turn it against stop to check the mechanical unlocking. Open the door by pressing the lever handle.
- Check several times.

If necessary, disassembling of the lock should be made in the reverse order.

5. MAINTENANCE

Warning!
• Do not use the lock at power supply voltage other than specified in its technical specification.
• Do not use the lock in operation conditions other than specified in the following Manual.
• Do not use the lock in hostile environment with atmospheric content of acids, bases, oils, etc.

The lock is a normally-opened device, which means that de-energized lock is unblocked.

When you open the door from the body of the lock is automatically slid out the locking mechanism lever. When the door is closing, the locking mechanism lever is recessed into the lock body, and the locking bolt automatically moves out, and the door is locking.

The lock is locked by applying and holding a voltage of +12 V on the terminal block contacts of the lock (potential operation mode of the ACS controller). When the lock is locked, the possibility of rotating the lever handle is blocked.

To unlock the lock use one of the following ways:

- turn the key in the mechanism of secrecy all the way and hold in this position until the door is opened;
- remove voltage +12V to the terminal block contacts of the lock.

After unlocking the lock, the door is opened by turning the lever handle (approximately 20°). When you turn the lever handle, the locking bolt slides inside the housing and you can open the door. The opening of the door is monitored by the state of the door sensor (reed switch) or by the state of the terminal block contacts (open circuit of the lock).

6. PERCo WARRANTY

PERCo (the Manufacturer) warrants that the **LB-72.4** electromechanical mortise door lock (the Product) complies with applicable statutory safety requirements, electromagnetic compatibility provided that the instructions on storage, installation and operation, given in the Assembly & Operation Manual are observed.

The warranty period is 5 (five) years commencing from the date of sale.

Should there be no date of sale on the warranty card, the warranty period shall commence from the date of manufacture.

Within the warranty period the Product is repaired free of charge at the Manufacturer's site.

The Warranty does not cover Products with external mechanical damages or disassembled by the Customer.

Upon lock purchase request the date of sale stamp in the warranty certificate and check the completeness of the delivery set as per the Manual.

In case any questions arise during the Product assembly or operations, PERCo Company is always ready to give you necessary technical support.

PERCo

Polytechnicheskaya str. 4, block 2
194021, Saint-Petersburg, Russia

Tel: +7 812 247 04 64

e-mail: export@perco.com
support@perco.com

www.perco.com

Electromechanical Mortise Door Lock LB-72.4



Certificate and Operation Manual

www.perco.com



POCC. RU.СП26.Н03587
TY 4981-049-88226999-2014