

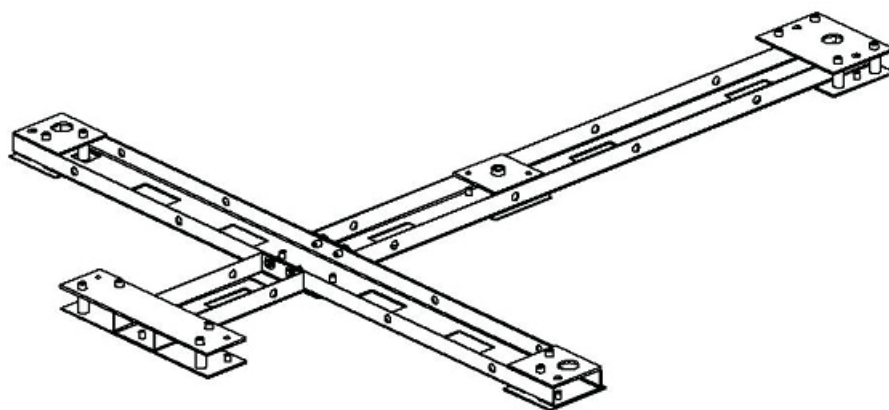

## Foundation Frame

# RF-01

INSTALLATION MANUAL



CE



# **Foundation Frame**

***RF-01***

**Installation Manual**

**CE**



## 1 GENERAL DATA

Foundation frame **PERCo-RF01 0-01** (hereinafter – the frame) is designed to ease installation as well as achieve quality and precision in installation of full-height turnstiles of **RTD-15** series, ensuring correct operation and reliability of the turnstile. It is recommended to use the frame for outdoor application of the turnstiles.

Operation of the frame is allowed at ambient air temperature from  $-40^{\circ}\text{C}$  to  $+55^{\circ}\text{C}$  and relative air humidity of up to 98% at  $+25^{\circ}\text{C}$ .

The frame in the original package should be transported in closed freight containers or other closed type cargo transport units. During storage and transportation of the same type boxes can be stacked no more than 10 layers high.

Storage of the frame is allowed in dry indoor facilities at ambient air temperature from  $-40^{\circ}\text{C}$  to  $+45^{\circ}\text{C}$  and relative air humidity of up to 98%. The environment should be free of acid and alkali vapours and gases that cause corrosion.

Overall dimensions of the assembled frame (Fig. 1)

(Length × width × height).....	1790×1550×70 mm
Net weight .....	max. 25 kg
Weight (gross) .....	max. 51 kg

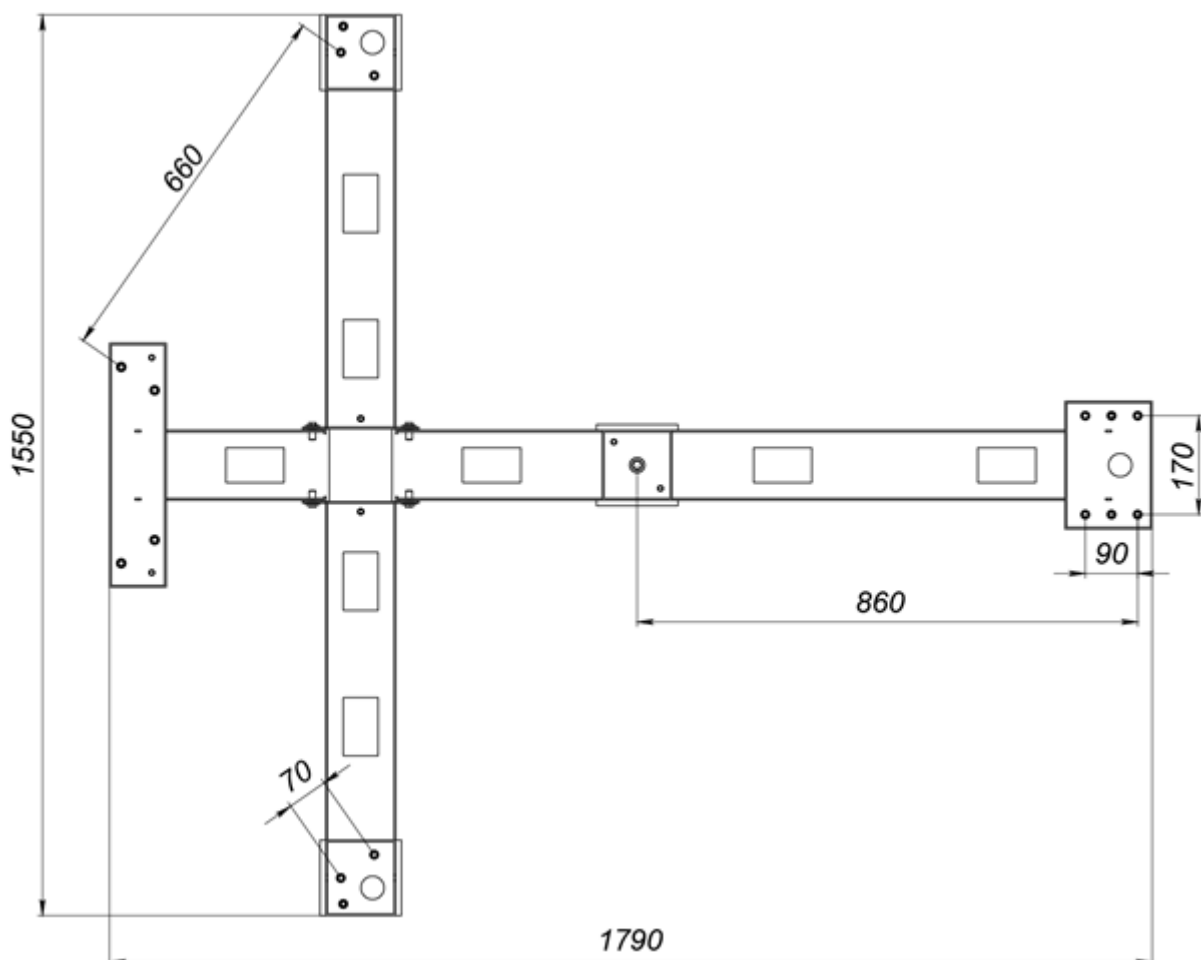

Figure 1. Overall and installation dimensions of the frame

## 2 DELIVERY SET

### Basic equipment:

Shell 1 .....	1
Shell 2 .....	1

### Installation tools:

Bolt M8×20 .....	6
Adjustment pin M8×120 .....	8
Washer 8 (extended) .....	6
Bolt M10×50 <sup>1</sup> .....	12
Screw M16×60 <sup>1</sup> .....	1
Washer 10 <sup>1</sup> .....	12
Washer 16 <sup>1</sup> .....	1

### Technical documentation:

Installation manual .....	1
---------------------------	---

### Package:

Box .....	1
-----------	---

---

<sup>1</sup> Fasteners designed to install the RTD-15 turnstile on the mounting frame.

### 3 INSTALLATION

It is recommended:

- to perform works by at least 2 skilled workers;
- to use concrete with a strength class of at least B22.5 for concrete pouring of foundation ground.
- to use installation tools: wrenches S13 and level.

When mounting the frame, it is recommended to follow the following sequence of operations:

1. Unpack the frame and check the delivery set.
2. Prepare foundation for the frame, sized 2000×1700 mm 200-250 mm deep, by erecting shuttering on the perimeter, orienting it in accordance with layout of your passage area; the bedding should be leveled, back-filled with gravel and sand, and compacted.
3. Assemble the foundation frame in accordance with Figures 2.
4. On the frame it is additionally recommended to insert and symmetrically fix horizontal pieces of reinforcement 600-700 mm long through holes Ø16 mm in the vertical walls of shell 1 and shell 2.
5. Mount the assembled frame on the prepared foundation, oriented in accordance with layout of your passage area; under adjustment pins put installation supports minimum 50 mm thick (adjust position relatively to shuttering taking into account concreting level).
6. Check horizontal alignment of the frame at turnstile fixing points, and if necessary adjust it using gaskets and pins supplied in a standard delivery set; maximum allowable plane tolerance should not exceed 1.5 mm.
7. Using L-shaped installation pins and holes in shell 1 and shell 2 fix the frame relatively to the foundation (installation pins are not included in standard delivery set); prior to casting the frame must be properly fixed against movements in any direction.
8. Lay electric raceways in accordance with turnstile cables layout (Ref. Assembly and Operation Manual of the **RTD-15** turnstile) and passage area layout.
9. Fix the electric raceways relatively to the frame; ends of the electric raceways should be above casting level; it is recommended to provide pulling wires to lay cables in the electric raceways in advance. Outside the foundation frame the electric raceways are laid in accordance with the passage area layout.
10. Pour concrete to the foundation using concrete of strength class of minimum B22.5, up to the upper level of threaded bushes as shown in Figure 3.



#### **Attention!**

- Threaded holes of the frame (fixing points of the turnstile) should be blinded with installation bolts to prevent concrete ingress into them during concreting.
- If the installation surface requires an additional coating, for example, tiling, the pouring is done lower in level taking into account the thickness of the tile and the bonding solution.

11. During concreting make sure all space of the foundation is filled with concrete, including space under frame itself. Time for the concrete to set-off before the turnstile mounting is determined by climate conditions and concrete type.

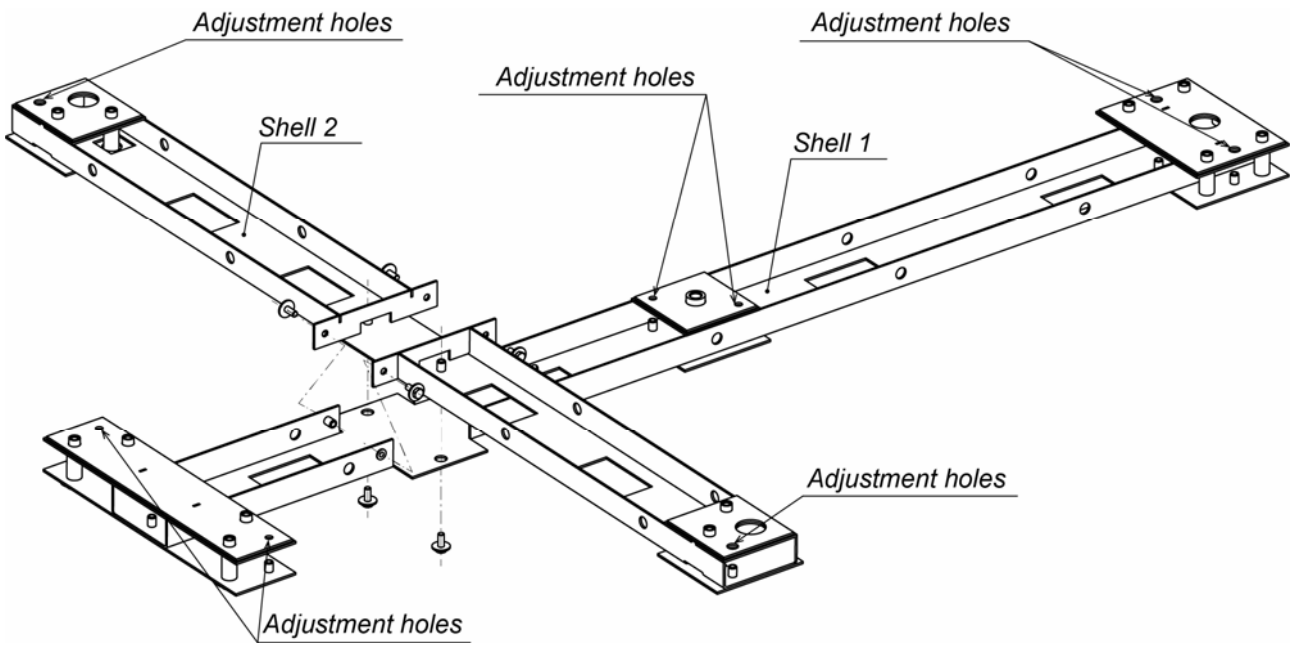

**Figure 2. Assembly scheme.**

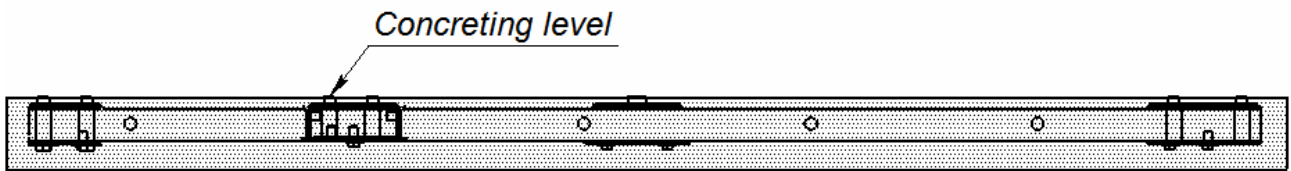

**Figure 3. Frame installation layout**





# **PERCo**

Polytechnicheskaya str., 4, block 2  
194021, Saint Petersburg  
Russia

Tel: +7 812 247 04 64

**E-mail: [export@perco.com](mailto:export@perco.com)  
[support@perco.com](mailto:support@perco.com)**

**[www.perco.com](http://www.perco.com)**



[www.perco.com](http://www.perco.com)