

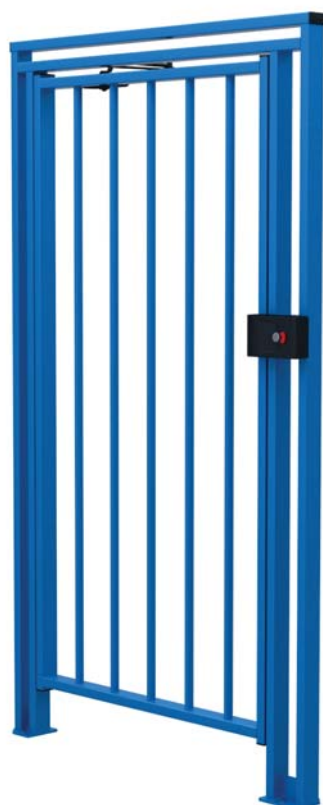

Full Height Security Gate

WHD-16

INSTALLATION AND OPERATION MANUAL



CE



Full Height Security Gate

WHD-16

Installation and Operation Manual

CONTENT

1	APPLICATION	3
2	OPERATION CONDITIONS	3
3	TECHNICAL SPECIFICATIONS	4
4	DELIVERY SET	5
4.1	Standard delivery set	5
4.2	Optional equipment	5
5	DESIGN AND OPERATION	8
5.1	Main features	8
5.2	Design and operation	8
6	MARKING AND PACKAGING	9
7	SAFETY REQUIREMENTS	9
7.1	Installation safety requirements	9
7.2	Operation safety requirements	9
8	INSTALLATION	10
8.1	General recommendations	10
8.2	Installation tools	10
8.3	Installation of standard and optional equipment	10
8.4	Installation of the gate	11
9	OPERATION INSTRUCTIONS	13
10	TRANSPORTATION AND STORAGE	14

Dear customers!

*We thank You for choosing the security gate manufactured by PERCo.
You have purchased a high quality product, which will be long lasting
in operation provided that installation and operation rules are observed.*

The Installation and Operation Manual (hereinafter – the Manual) contains the instructions you need for safety transportation, storage, installation, operation, and maintenance of the **WHD-16 full height security gate** (hereinafter – the gate).

The product installation should be carried out with strict accordance to this Manual.

Abbreviations:

PS – power supply,
ACS — access control system.

1 APPLICATION

The **WHD-16 full height security gate** is designed for management of pedestrian flows and access control at entrance points of facilities and areas with high security requirements and necessity for full vertical closure of the passageway.

It is advisable to determine the number of the gates sufficient for fast and convenient pedestrian passage through the entrance point on basis of the gate throughput capacity (sect. 3 of the Manual).

2 OPERATION CONDITIONS

The gate, in accordance with the resistance to environmental exposure, complies with GOST 15150-69, category N2 (outdoor operation).

Operation of the gate is allowed at ambient temperature from –30°C to +40°C and relative air humidity of up to 98% at +25°C.

3 TECHNICAL SPECIFICATIONS

Electromechanical lock:

Operating voltage	11.5÷14 V DC (AC)
Consumption current	3 A
Power consumption	36 W
Throughput rate in the single passage mode	12 persons/min
Average daily throughput in the single passage mode	2,000 persons/day
Passageway dimensions (H × W)	960×2000 mm
Mean time to failure	min. 1,000,000 passages
Mean lifetime	min. 8 years
Overall dimensions (H × W × D)	1224×350×2093 mm
Net weight	max. 70 kg

4 DELIVERY SET

4.1 Standard delivery set

Primary parts:

Assembled gate with rim electromechanical lock	1
Set of keys to electromechanical lock	1
Door closer with fasteners	1

Assembling tools:

Hex key SW4	1
-------------------	---

Technical documentation:

Gate installation and operation manual	1
Gate certificate	1
Door closer installation and operation instructions	1
Electric rim lock installation and operation instructions	1

Package:

Box	1
-----------	---

4.2 Optional equipment

The following optional equipment and assembling tools could be included in the delivery set on request.

Power supply	1
MB-16 full height railing sections	determined by the customer
Fasteners ¹	determined by the customer
Anchor bolt (SORMAT PFG IR 10-15, Finland) ²	4



Note:

Technical characteristics of optional equipment are given in the respective documentation included in the delivery set of each optional product.

¹ Plates and brackets to join the gate with the **RTD-16** turnstile, the **MB-16** railing section or a wall. Types, number and mounting order of the fasteners depend on the entrance point design and are set out in the installation documentation for a particular combined order, beyond the scope of this Manual.

² For solid concrete floors or similar foundations. Installation of the gate on other types of foundations may require different mounting hardware.

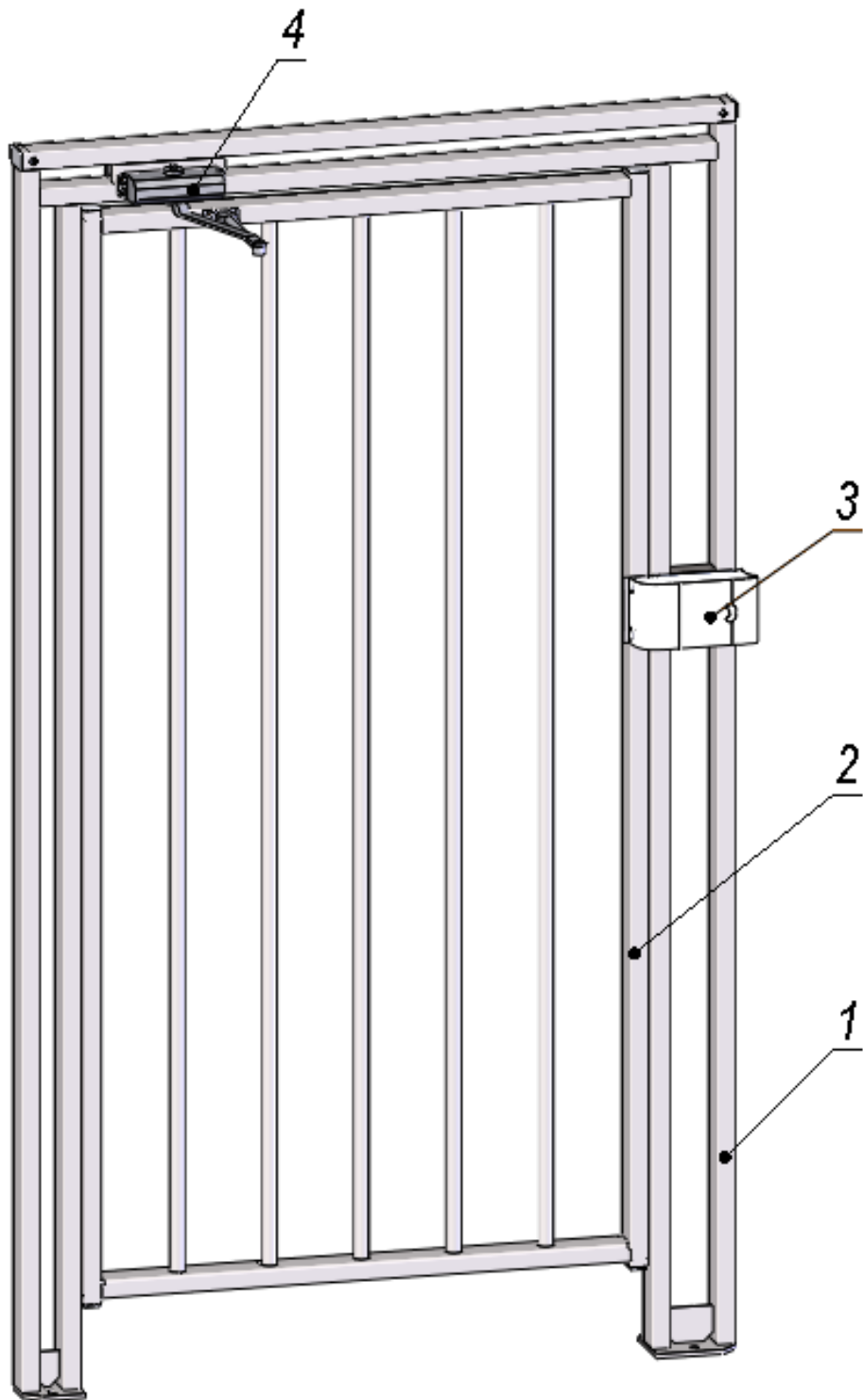

Figure 1. General view of the WHD-16 gate

1 – frame; 2 – leaf; 3 – electromechanical lock; 4 – door closer

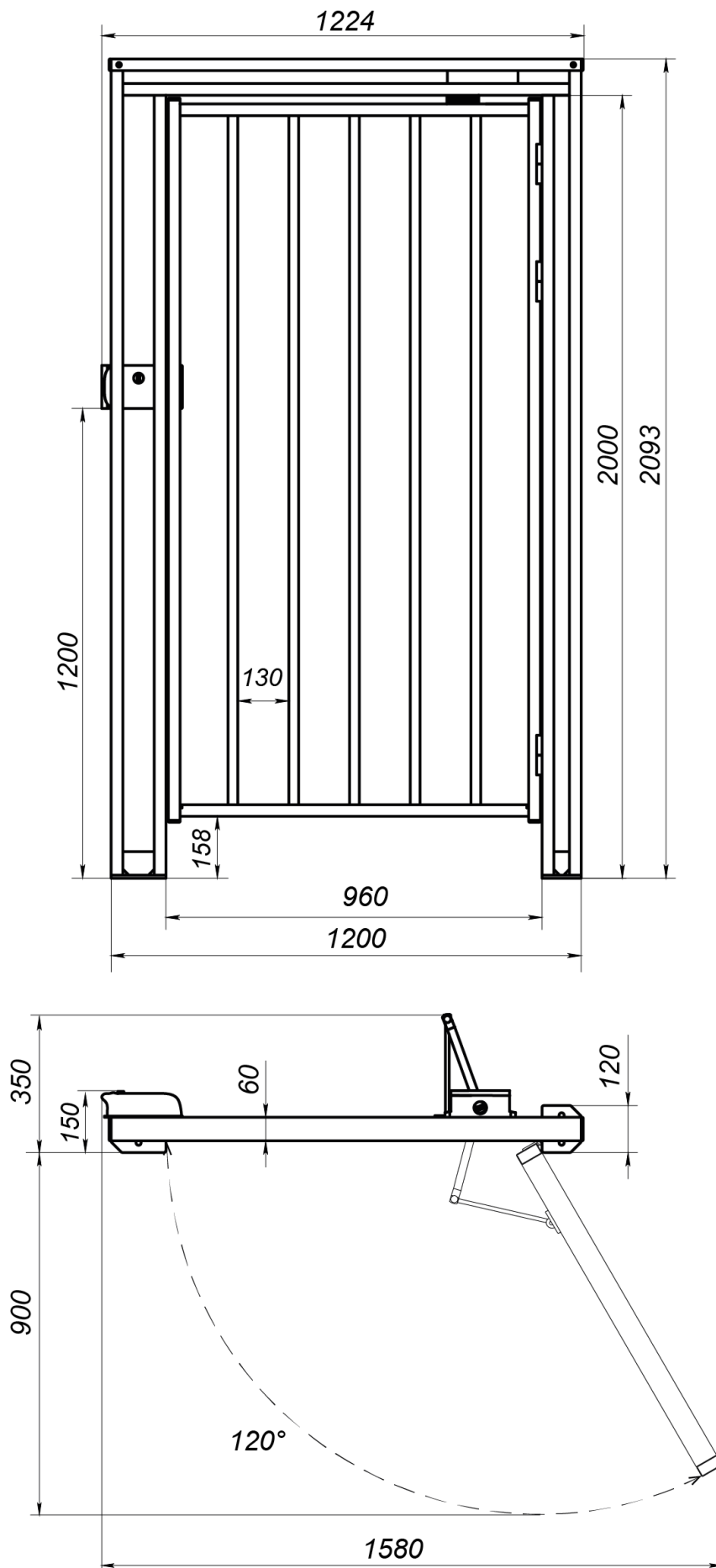

Figure 2. Overall dimensions of the WHD-16 gate

5 DESIGN AND OPERATION

5.1 Main features

- possibility of remote gate unlocking;
- leaf reset by a hydraulic door closer after the passage;
- wide passageway to provide controlled passage for people in wheelchairs (with an attendant) and deliveries of large or bulky items;
- Combined coating of all gate elements with zinc and powder paint ensures high corrosion resistance and long years of service in harsh environments;
- durable polymeric powder coating protects the outside appearance;
- unity of design with **RTD-16** full height turnstiles and **MB-16** railings enables various configurations of the entrance point to meet any required layout and dimensions;
- together with **RTD-16** full height turnstiles, the gate can be used as an emergency exit.

5.2 Design and operation

The gate design is shown in Fig. 1. Overall dimensions of the gate are given in Fig. 2. Unless noted otherwise, the position numbers in the Manual agree with Fig. 1. The gate consists of: frame (1), leaf (2), electromechanical lock (3), door closer (4).

The *frame* (1) consisting of three joined vertical posts and *the leaf* (2) are made of durable aluminium profile. The assembled gate is delivered with the *rim electric lock* (3) mounted on the frame. During the installation, the hydraulic *door closer* (4) is mounted on the frame and the leaf. The gate is mounted on the floor with anchor bolts driven through four mounting holes in the post flanges.

In the home position (closed for entrance and exit) – the leaf provides complete closure of the passageway between the posts, the lock is locked up. After the lock is unblocked, the gate can be opened outwards (the maximum opening angle of the leaf is 120°).

The lock is unblocked **mechanically**, by use of a key or by briefly pressing a button located on the lock case (on the inside of the door) or **remotely** by emitting a control signal from an external device (ACS-controller) with a voltage of 12V and a duration 0.5 - 1 sec. The lock can be in the unblocked state indefinitely, while the leaf is open.

The lock is blocked automatically when the leaf is returns to its home position. At the same time, the unblocking mechanism of the lock is cocked for a next opening.

To open the lock with a key from the inside (the side of the door on which the lock case is located), it is necessary to turn it counterclockwise until it stops and press the control button.

If you then remove the key from the lock cylinder (in this leftmost position), subsequent unblocks can be made by pressing a button without using a key or remotely by applying a control voltage.

If you turn the key in the lock clockwise until it stops (in the rightmost position) and then remove it, the operation of the control button is blocked and the lock can be opened again only with a key or remotely by applying a control voltage.

To open the lock with a key from the outside of the gate, turn the key clockwise until it stops - the lock is unlocked and the leaf can be opened.

6 MARKING AND PACKAGING

The gate marking contains the product name, its date of manufacture and serial number. Optional accessories and items are marked according to their respective technical documentation.

The standard delivery set is packed into a package box to protect the gate from damage during storage and transportation.

Box overall dimensions (L × W × H) 221×130×24 cm
Grosse weight max. 90 kg

7 SAFETY REQUIREMENTS

7.1 Installation safety requirements

The installation should be carried out only by the qualified personnel after careful study of this *Manual*.



Warning!

- All the cables should be connected up when the power supply is switched off from the AC mains.
- Only serviceable tools should be used for installation.
- Observe general electrical safety rules when laying out the cables.
- Before the turnstile first power on make sure its installation and connection have been made accordingly.

Power supply unit installation must be made in accordance with the safety rules stipulated in its certificate.

7.2 Operation safety requirements

Observe general electrical safety rules when operating the electromechanical lock.



Warning!

- Do not use the gate under conditions that do not comply with the requirements of Chapter 2 of this Manual.
- Do not use the electromechanical lock at supply voltage that does not comply with the requirements of Chapter 3 of this Manual.
- To avoid injuries – do not step or hang on the gate crossbeams, do not pass hands or legs between the wicket elements during the gate operation etc.

Safety requirements on the power supply units, electromechanical lock and door closer operation are shown in their certificates.

8 INSTALLATION



Attention!

The manufacturer will not accept liability for any damage to the gate or other equipment, or otherwise loss caused as a result of improper installation, and will dismiss any claims by the customer should the installation work be carried out not in accordance with this Manual.

8.1 General recommendations

Proper installation is critical to performance and serviceability of the gate. We strongly advise to study this section before installation work is commenced, and follow the instructions to the letter over the course of the installation.

Installation to be carried out by at least two persons qualified in assembly and electric work.

We advise:

- mounting the gate on flat, solid concrete floors (grade 400 or higher, SCS B22.5), stone or similar foundations at least 150 mm thick;
- employing reinforcing elements 250×250×400 mm for soft grounds;
- using relevant mounting hardware for installation on different foundations;
- making sure the mounting foundation is horizontal and flat; the flatness deviation must not exceed 1.5 mm;
- installing optional equipment in the sequence given in sect. 8.3.

8.2 Installation tools

- 1.2÷1.5 kW hammer drill;
- Ø16 mm hard-alloyed drill bits;
- Horn-type and socket wrenches: S17, S13;
- Allen keys SW4, SW6;
- №2 cross-tip screwdriver, 150 mm;
- №5 straight- slot screwdriver, 150 mm;
- 2 m tape-measure;
- level gauge;
- two stepladders (4 steps or more).



Note:

Use of other similar tools is allowed providing they do not reduce quality of the installation work.

8.3 Installation of standard and optional equipment

Carry the installation work in accordance with respective manuals and below guidelines. Exact installation sequence depends on the chosen entrance point layout.

For installation of the gate together with the **MB-16** full height railings, we recommend the following installation sequence:

1. the gate;
2. standard sections of the full height railing;
3. extension sections of the full height railing.

For installation of the gate together with the **RTD-16** full height rotor turnstiles and the **MB-16** full height railings we recommend the following installation sequence:

1. the turnstile foundation frame;
2. the turnstile;
3. the gate;
4. standard sections of the full height railing;
5. extension sections of the full height railing;
6. the turnstile protective canopy.

Contact **PERCo** Technical Support Department if you need further consulting.

8.4 Installation of the gate

Further in this section each installation operation is described in compliance with the above guidelines (sect. 8.1).

Recommendations on how to prepare mounting holes in the foundation (the mounting surface) are given with regard to anchor bolts for solid concrete floors or similar foundations (sect. 4.2).

1. Unpack the gate; check the delivery set against section 4 of the Manual.
2. Mark out mounting holes and cable ducts. Through cable ducts lay necessary power cable to the electromagnetic lock (and also if necessary, cable to the door sensor) (Fig. 3).

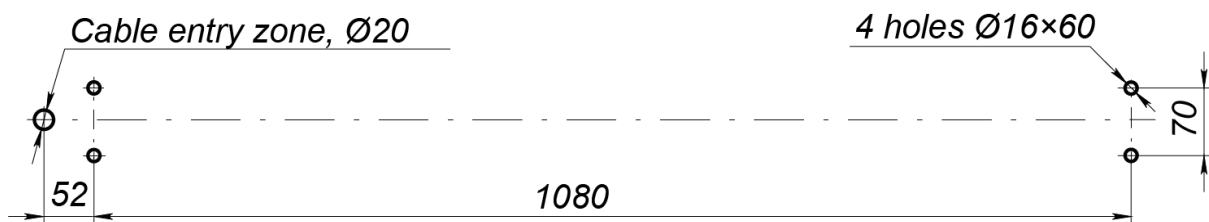

Figure 3. Mounting hole pattern

3. Insert sleeves for anchor bolts into the holes so that they do not stick out above the floor surface.



Attention!

Be extra cautious and careful when carrying out further work. Prevent the gate from falling.

4. Mount the gate so that the flanges are on their respective mounting holes, fix the gate with the anchors observing verticality with a level gauge and using joint liners when necessary.
5. Install the door closer on the mounting holes in the frame and the leaf. If necessary, adjust the leaf closing speed with the speed-adjusting screws (see installation and operation instructions for the door closer).
6. When using a gate in the ACS, connect the power supply and ACS-controller to the electromechanical lock of the gate (see Figure 4). It is recommended to use a power supply with a voltage of 12V / 3A (DC or AC).



Attention!

The duration of the control signal from the ACS-controller must be at least 0.5, but not more than 1 second. A longer control signal can cause the lock malfunction. To reduce the probability of lock failure, it is recommended to limiting the current in the power supply circuit of the lock – install a resistor R1 (12 Ohm / 10 W, Figure 4).

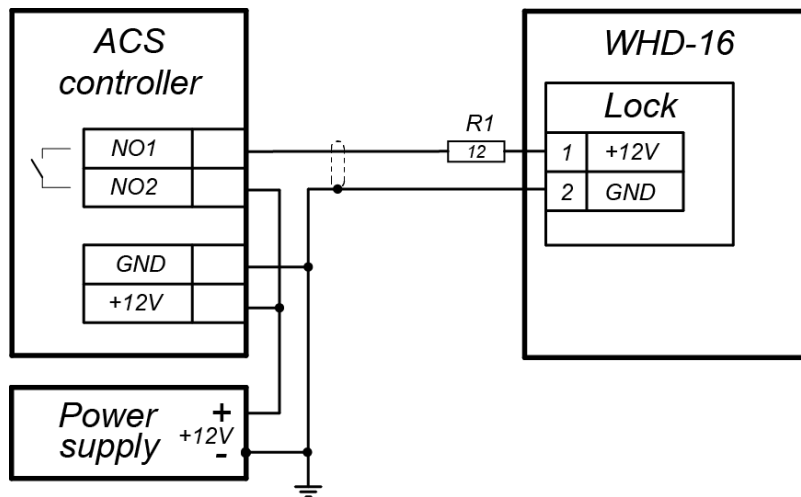

Figure 4. Recommended connection layout of the lock

7. When the gate is operating in the ACS to monitor of the "Closed" position it is recommended to install a door sensor (reed switch). The magnetic part of the sensor is installed in the leaf (it is recommended the upper part of the leaf), and the sensor itself is installed in the gate frame.
8. Clear the passage area from foreign objects and check the operation of the lock and door closer according to their operational documentation.

The gate is ready for operation.

9 OPERATION INSTRUCTIONS



DON'TS:

- DO NOT carry through the gate items exceeding the passageway dimensions;
- DO NOT subject the gate to strong impact;
- DO NOT clean the gate with substances that may cause damage or corrosion of its parts.

The gate leaf can be unlocked by the key of the lock or by pressing the button on the lock or remotely by the control signal from the ACS. Locking of the gate is performed automatically when the leaf is returned to its home (closed) position.

The gate lock can work in 2 modes:

- *normal*: outside the lock is opened with a key or remotely, from the inside the lock is opened by pressing the button and remotely.
- *with the blocked exit button*: opening from the outside, as in the normal mode, and from the inside the lock is only opened by the remote control signal, since the exit button is fixed with the key in the normal position.

The choice of the lock operation mode is carried out by a key from the inside through the cylinder mechanism controlling the exit button. If you turn the key counter-clockwise until it stops and then remove it from the lock, the lock will go into *normal* mode, if you turn it clockwise to the stop and take it out, then the lock will go into the mode with the blocked exit button.

The absence of voltage does not affect the operation of the button or key.

10 TRANSPORTATION AND STORAGE

The gate in the original package should be transported in closed freight containers or other closed type cargo transport units.

During storage and transportation the boxes can be stacked no more than 2 layers high.

The gate should be stored indoors at ambient temperature from -40°C to $+45^{\circ}\text{C}$ and relative air humidity below 98% at $+25^{\circ}\text{C}$. The environment should be free of acid and alkali vapours or corroding gases.

After transportation or storage of the gate at below-zero temperatures or high air humidity, the installation works should not start before the gate in the original package has been kept for 24 hrs under the environmental conditions referred to in Section 2 of the Manual.

PERCo

Polytechnicheskaya str., 4, block 2
194021, Saint Petersburg
Russia

Tel: +7 812 247 04 64

**E-mail: export@perco.com
support@perco.com**

www.perco.com



www.perco.com