

PERCo LB-series locks

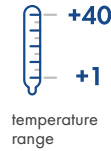

Application

The LB-series locks are electromechanical mortise locks designed for operation as operating devices in access control systems to lock light and medium-thick doors in offices and administrative buildings. The locks can be installed in wooden and non-metallic doors 38-50 mm thick.

See the table below for discrepancies of the locks:

Lock type	Control mode	Center-to-center spacing
LB85.3	Unlocks when powered (normally closed lock)	85 mm
LB85.4	Unlocks when deenergized (normally open lock)	85 mm

Main features

Main features of LB-series locks:

- the lock has a unique design that allows connecting the lock control cable through the strike plate in the door frame, not through the door leaf, which makes installation easier
- when the locks are connected to the PERCo ACS controllers (CT/L04.1, CT/L04.2, CL05.1, CL05.2, CL201.1), the lock operation can be maintained without using a door sensor (reed switch), the lock contact group registers the fact of opening / closure of the door



PERCo LB-series locks

- mechanical release with a key
- ACS-focused design
- low power consumption
- universal lock enables its installation on both right-handed and left-handed doors
- standard center-to-center spacing (72 mm, 85 mm) allows installing locks instead of mechanical locks without the need to change or reconstruct the door
- the lock design allows using almost all types of lever handles, plates, and lock cylinders that are available in the market;
- lock is resistant to self-opening (for instance, as a result of a hard kick on the door)
- details and lock body are corrosion-resistant coated
- lock does not require preventive maintenance and lubrication from the customer for the entire period of operation

Locking and unlocking are performed upon signals from the ACS controller. Control signals are sent to the deadlock contacts through the contact group on the strike plate. After unlocking, the door can be opened by turning the handle (approximately by 20°), the bolt goes into the door frame and the door can be opened.

When the door is opened, the locking lever moves out automatically. When the door closes, the locking lever slides into the door frame and the locking bolt moves out automatically and locks the door.



Locking lever

Locking bolt moved out

Operating conditions

The lock with regard to resistance to environmental exposure complies with GOST 15150-69, category NF4 (operation in premises with climate control). Operation of the lock is allowed at ambient air temperature from +1 °C to +40 °C and at relative air humidity of 80% at +25 °C.

It is a serially produced product certified for compliance with applicable Russian and European CE standards.

Delivery set

Mortise electromechanical lock	1
Strike plate with contact group	1
Mounting kit	1
Certificate, Assembly and Operation Manual	1
Marking template (2 pcs)	1 set
Optional equipment (upon request)	
Lock cylinder with a set of keys	1
Handles with decorative plates	1 set

PERCo LB-series locks

Technical specifications

Operating voltage	12±1 V DC	
Current consumption	max. 120 mA	
Power consumption	max. 2 W	
Cylinder type	pin-typee	
Locking bolt slide out distance	min. 15 mm	
Operating mode	LB85.3	normally closed
	LB85.4	normally open
Overall dimensions	LB85.3, LB85.4	94x22x187 mm
Center-to-center spacing	LB85.3, LB85.4	85 mm
Lock weight	max. 0.5 kg	
Mean time to failure	min. 200,000	
Mean lifetime	8 years	

Connection

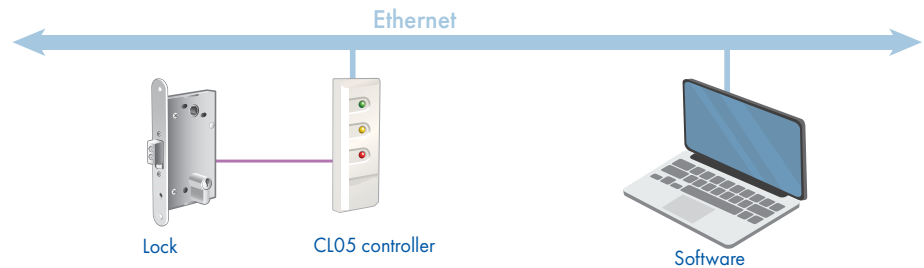

The lock is operated in potential mode. For normally closed locks unlocking is performed by sending control voltage, for normally open - removing control voltage.

To unlock the door, the ACS controller sends a control signal to the lock and holds it till the moment the door is opened (ACS controller potential operating mode).

The door opening / closure fact can be registered by the door sensor (reed switch) or by using the contact group (CT/L04.1, CT/L04.2, CL05.1, CL05.2, CL201.1 lock controller).

When the lock is connected to the ACS controller, it is recommended to install BZW06-15B or P6KE16CA or a similar suppressor on the contact group terminal block. The suppressor is designed to protect the ACS controller.

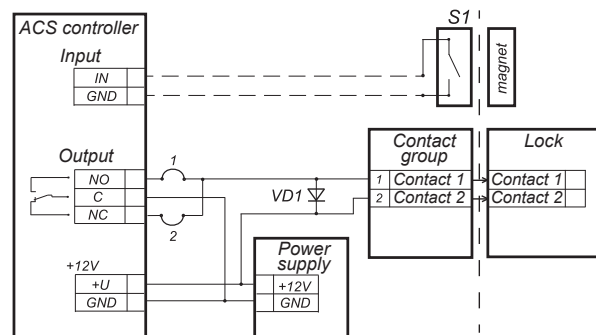

Variants of lock connections:

- 1 - lock opens automatically when powered (LB85.3)
- 2 - lock opens automatically when de-energized (LB85.4)
- VD1 - 15-18 V suppressor (BZW06-15B, P6KE16CA)
- S1 - door opening detector (reed switch) can be not installed when using CT/L04.2, CL05.1, CL201.1 controllers

LB-series lock connection to the controller

PERCo LB-series locks

Overall dimensions

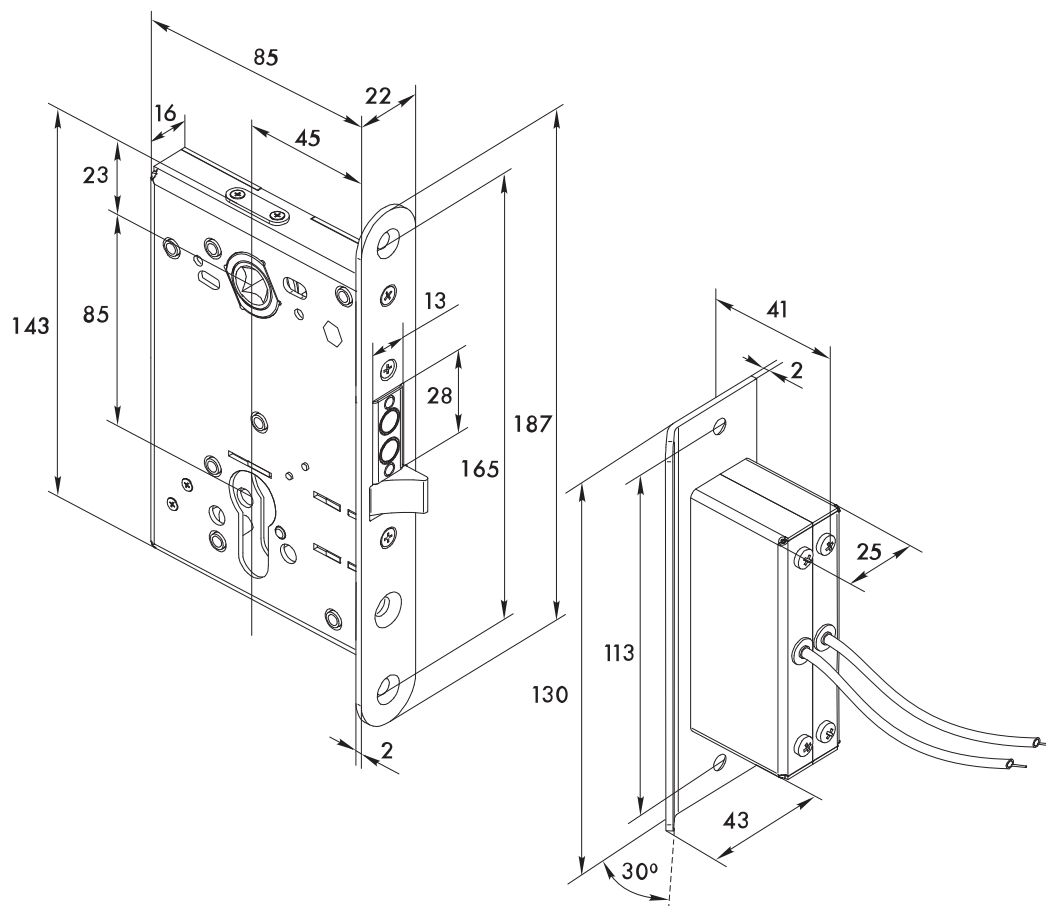

Mounting

In order to provide stable lock operation, it is necessary to ensure the accuracy of the installation of the strike plate with the terminal block relative to the locking bolt ± 3 mm vertically and ± 1 mm horizontally. The lock operates normally if the spacing between the forend plate and the strike plate is from 1 to 5.7 mm (recommended clearance of 3 mm).

The channel of the strike plate can be located symmetrically relative to cross-section of the locking bolt. The locking mechanism lever should not get into the channel of the strike plate. Otherwise, at closing the door, it can get locked with the moving lever and then it will be impossible to open the door without damaging the lock.

Upon delivery, the locking mechanism lever is oriented for installation on the left door. To install the lock on the right door, its position should be changed. For this purpose:

- remove the forend plate by unscrewing the three fixing screws
- remove the locking mechanism lever with the axle
- turn the lever 180° and lower its axis
- place the lever into place with the axle in the opposite slot
- install the forend plate and secure it with screws
- length of cylinder mechanism bolt must not exceed 50 mm

Lock design allows using standard cylinder mechanisms of European standards such as EuroDIN (VDIN 18254), or 8809, 8209, 8259 produced by ISEO (Italy), D-series mechanisms produced by Wilco Supply (254 – 274 – 294, 453, 454, 554).

PERCo LB-series locks

Warranty

The warranty period is 5 (five) years commencing from the date of sale, unless otherwise determined in the delivery contract of the Product. In case of sale and installation of the equipment by authorized PERCo dealers and service centers, the warranty starts from the date of commissioning.

Should there be no date of sale on the warranty card, the warranty period shall commence from the date of manufacture specified in the Certificate and on the Product label.